

DG401/403/405

Low-Power, High-Speed CMOS Analog Switches

Features

- 44-V Supply Max Rating
- ± 15 -V Analog Signal Range
- On-Resistance— $r_{DS(on)}$: 20 Ω
- Low Leakage— $I_{D(on)}$: 40 pA
- Fast Switching— t_{ON} : 100 ns
- Ultra Low Power Requirements— P_D : 0.35 μ W
- TTL, CMOS Compatible
- Single Supply Capability

Benefits

- Wide Dynamic Range
- Low Signal Errors and Distortion
- Break-Before-Make Switching Action
- Simple Interfacing

Applications

- Audio and Video Switching
- Sample-and-Hold Circuits
- Battery Operation
- Test Equipment
- Hi-Rel Systems
- PBX, PABX

Description

The DG401/403/405 monolithic analog switches were designed to provide precision, high performance switching of analog signals. Combining low power (0.35 μ W, typ) with high speed (t_{ON} : 100 ns, typ), the DG401 series is ideally suited for portable and battery powered industrial and military applications.

Built on the Siliconix proprietary high-voltage silicon-gate process to achieve high voltage rating and superior switch on/off performance, break-before-make is

guaranteed for the SPDT configurations. An epitaxial layer prevents latchup.

Each switch conducts equally well in both directions when on, and blocks up to 30 V peak-to-peak when off. On-resistance is very flat over the full ± 15 -V analog range, rivaling JFET performance without the inherent dynamic range limitations.

The three devices in this series are differentiated by the type of switch action as shown in the functional block diagrams.

Functional Block Diagrams and Pin Configurations

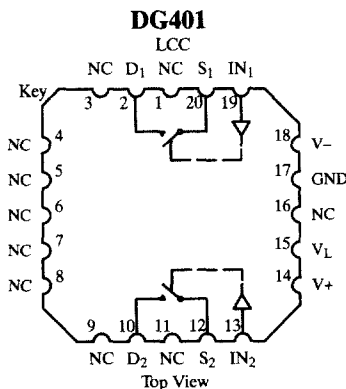
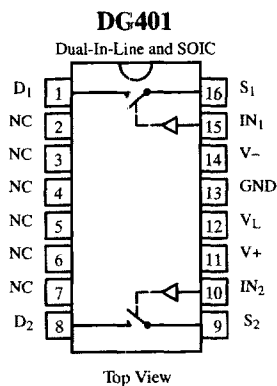

Two SPST Switches per Package

Truth Table

Logic	Switch
0	OFF
1	ON

Logic "0" ≤ 0.8 V
Logic "1" ≥ 2.4 V

Functional Block Diagrams and Pin Configurations (Cont'd)

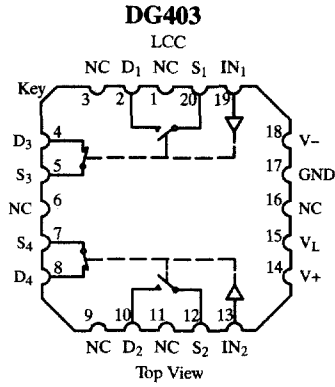
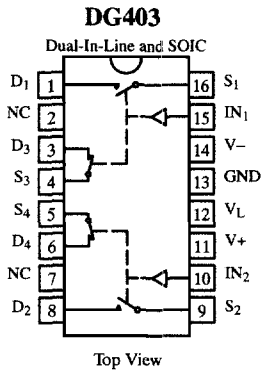

Two SPDT Switches per Package

Truth Table

Logic	SW ₁ , SW ₂	SW ₃ , SW ₄
0	OFF	ON
1	ON	OFF

Logic "0" ≤ 0.8 V
Logic "1" ≥ 2.4 V

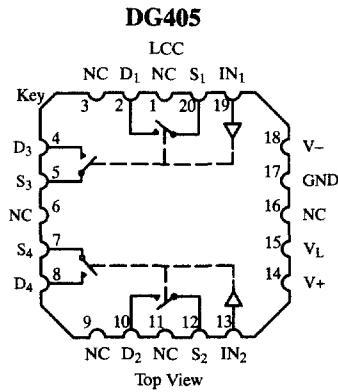
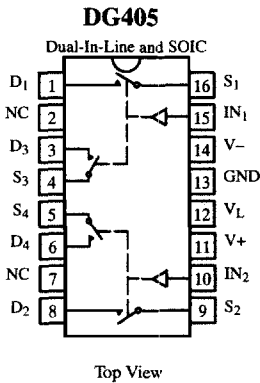

Two DPST Switches per Package

Truth Table

Logic	Switch
0	OFF
1	ON

Logic "0" ≤ 0.8 V
Logic "1" ≥ 2.4 V

Analog Switches

Ordering Information

Temp Range	Package	Part Number
DG401		
-40 to 85°C	16-Pin Plastic DIP	DG401DJ
-55 to 125°C	16-Pin CerDIP	DG401AK
		DG401AK/883
	LCC-20	DG401AZ/883
DG403		
-40 to 85°C	16-Pin Plastic DIP	DG403DJ
	16-Pin Narrow SOIC	DG403DY
-55 to 125°C	16-Pin CerDIP	DG403AK
		DG403AK/883
	LCC-20	5962-8976301M2A
DG405		
-40 to 85°C	16-Pin Plastic DIP	DG405DJ
	16-Pin Narrow SOIC	DG405DY
-55 to 125°C	16-Pin CerDIP	DG405AK/883
	LCC-20	5962-89961012A

Absolute Maximum Ratings

V+ to V-	44 V
GND to V-	25 V
V _L	(GND - 0.3 V) to (V+) +0.3 V
Digital Inputs ^a V _S , V _D	(V-) -2 V to (V+ plus 2 V) or 30 mA, whichever occurs first
Current (Any Terminal) Continuous	30 mA
Current, S or D (Pulsed 1 ms 10% duty)	100 mA
Storage Temperature	(AK, AZ Suffix) -65 to 150°C (DJ, DY Suffix) -65 to 125°C
Power Dissipation (Package)^b	
16-Pin Plastic DIP ^c	450 mW
16-Pin CerDIP ^d	900 mW
16-Pin SOIC ^e	600 mW
LCC-20 ^f	900 mW

Notes:

- Signals on S_X, D_X, or I_{NX} exceeding V+ or V- will be clamped by internal diodes. Limit forward diode current to maximum current ratings.
- All leads welded or soldered to PC Board.
- Derate 6 mW/°C above 75°C
- Derate 12 mW/°C above 75°C
- Derate 7.6 mW/°C above 75°C
- Derate 13 mW/°C above 75°C

Specifications^a

Parameter	Symbol	Test Conditions Unless Specified $V_+ = 15\text{ V}, V_- = -15\text{ V}$ $V_L = 5\text{ V}, V_{IN} = 2.4\text{ V}, 0.8\text{ V}^f$	Temp ^b	Typ ^c	A Suffix -55 to 125°C		D Suffix -40 to 85°C		Unit	
					Min ^d	Max ^d	Min ^d	Max ^d		
Analog Switch										
Analog Signal Range ^e	V_{ANALOG}		Full		-15	15	-15	15	V	
Drain-Source On-Resistance	$r_{DS(on)}$	$I_S = -10\text{ mA}, V_D = \pm 10\text{ V}$ $V_+ = 13.5\text{ V}, V_- = -13.5\text{ V}$	Room Full	20		35 45		45 55	Ω	
Δ Drain-Source On-Resistance	$\Delta r_{DS(on)}$	$I_S = -10\text{ mA}, V_D = \pm 5\text{ V}, 0\text{ V}$ $V_+ = 16.5\text{ V}, V_- = -16.5\text{ V}$	Room Full	3		3 5		3 5		
Switch Off Leakage Current	$I_{S(off)}$	$V_+ = 16.5\text{ V}, V_- = -16.5\text{ V}$ $V_D = \pm 15.5\text{ V}, V_S = \mp 15.5\text{ V}$	Room Hot	-0.01	-0.25 -20	0.25 20	-0.5 -5	0.5 5	nA	
	$I_{D(off)}$		Room Hot	-0.01	-0.25 -20	0.25 20	-0.5 -5	0.5 5		
Channel On Leakage Current	$I_{D(on)}$	$V_+ = 16.5\text{ V}, V_- = -16.5\text{ V}$ $V_S = V_D = \pm 15.5\text{ V}$	Room Hot	-0.04	-0.4 -40	0.4 40	-1 -10	1 10		
Digital Control										
Input Current V_{IN} Low	I_{IL}	V_{IN} under test = 0.8 V All Other = 2.4 V	Full	0.005	-1	1	-1	1	μA	
Input Current V_{IN} High	I_{IH}	V_{IN} under test = 2.4 V All Other = 0.8 V	Full	0.005	-1	1	-1	1		
Dynamic Characteristics										
Turn-On Time	t_{ON}	$R_L = 300\ \Omega, C_L = 35\text{ pF}$ See Figure 2	Room	100		150		150	ns	
Turn-Off Time	t_{OFF}		Room	60		100		100		
Break-Before-Make Time Delay (DG403)	t_D	$R_L = 300\ \Omega, C_L = 35\text{ pF}$	Room	12	5		5			
Charge Injection	Q	$C_L = 10,000\text{ pF}$ $V_{gen} = 0\text{ V}, R_{gen} = 0\ \Omega$	Room	60					pC	
Off Isolation Reject Ratio	OIRR	$R_L = 100\ \Omega, C_L = 5\text{ pF}$ $f = 1\text{ MHz}$	Room	72					dB	
Channel-to-Channel Crosstalk	X_{TALK}		Room	90						
Source Off Capacitance	$C_{S(off)}$		Room	12						pF
Drain Off Capacitance	$C_{D(off)}$		Room	12						
Channel On Capacitance	$C_D, C_{S(on)}$	Room	39							
Power Supplies										
Positive Supply Current	I_+	$V_+ = 16.5\text{ V}, V_- = -16.5\text{ V}$ $V_{IN} = 0\text{ or }5\text{ V}$	Room Full	0.01		1 5		1 5	μA	
Negative Supply Current	I_-		Room Full	-0.01	-1 -5		-1 -5			
Logic Supply Current	I_L		Room Full	0.01		1 5		1 5		
Ground Current	I_{GND}		Room Full	-0.01	-1 -5		-1 -5			

Notes:

- Refer to PROCESS OPTION FLOWCHART.
- Room = 25°C, Full = as determined by the operating temperature suffix.
- Typical values are for DESIGN AID ONLY, not guaranteed nor subject to production testing.
- The algebraic convention whereby the most negative value is a minimum and the most positive a maximum, is used in this data sheet.
- Guaranteed by design, not subject to production test.
- V_{IN} = input voltage to perform proper function.

4

Analog Switches

Typical Characteristics

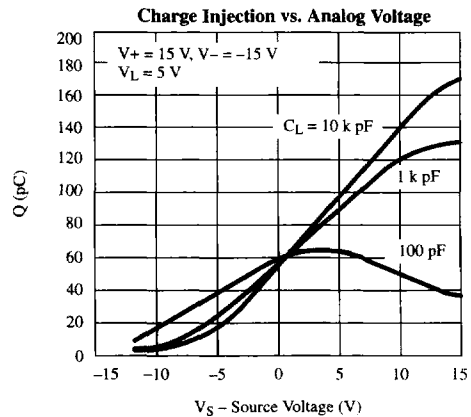
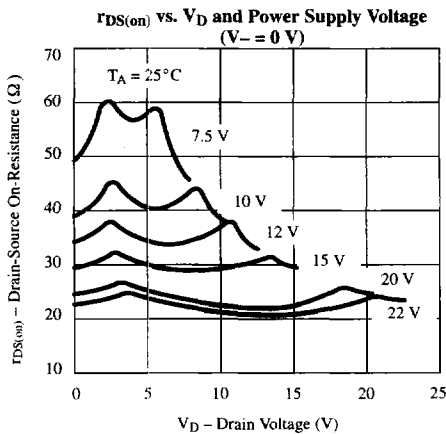
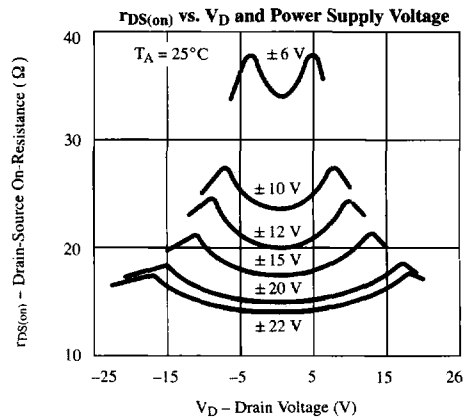
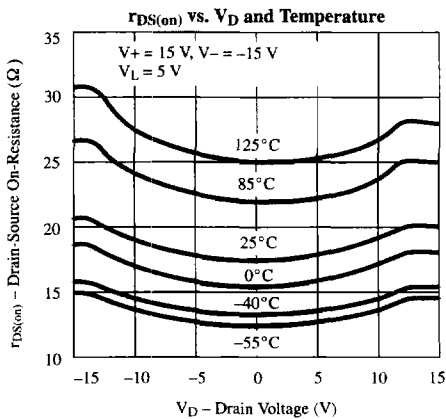
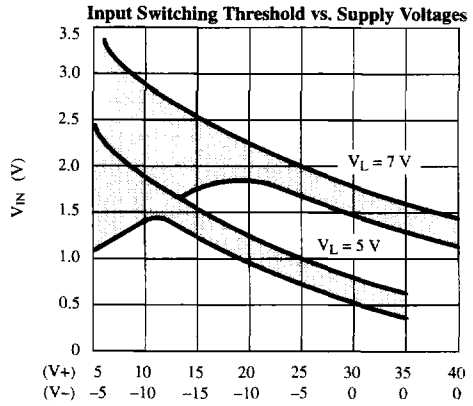
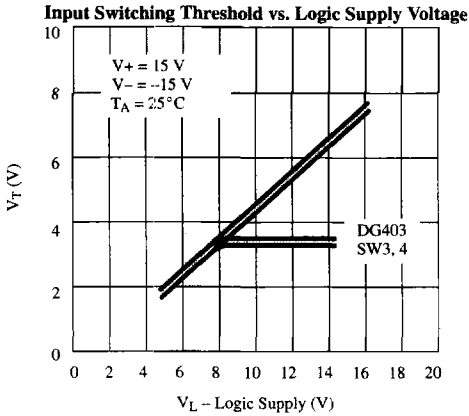

Typical Characteristics (Cont'd)

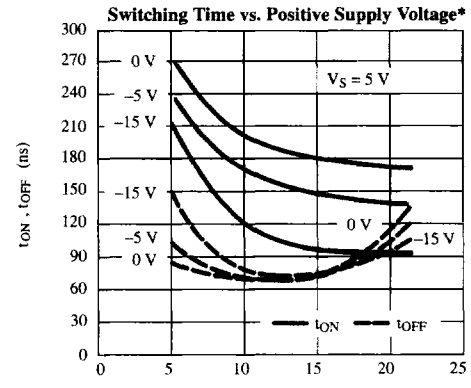
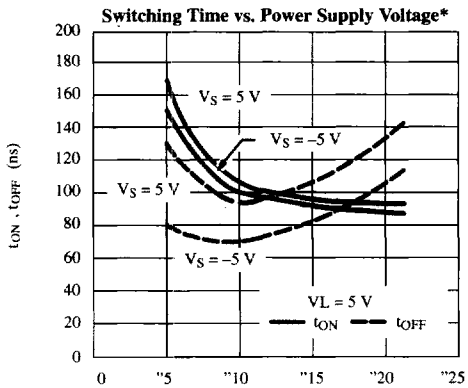
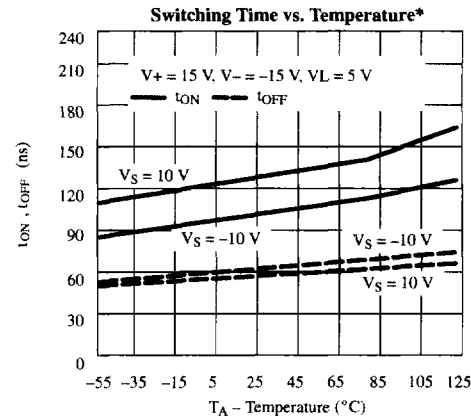
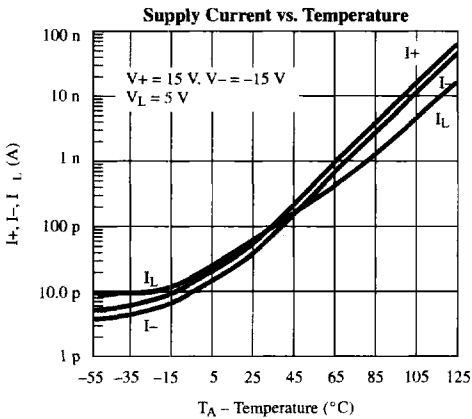
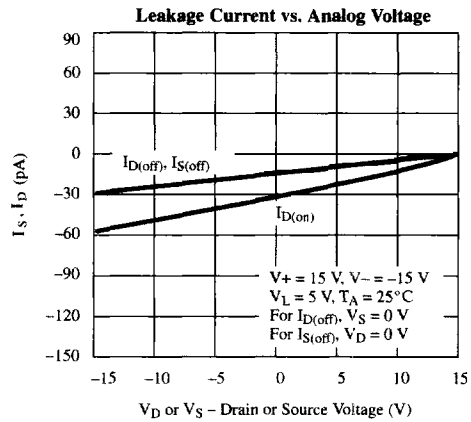
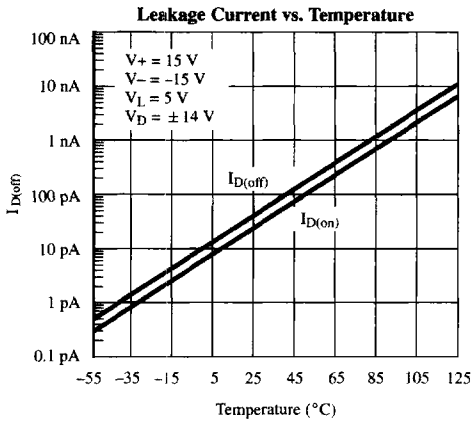

*Refer to Figure 2 for test conditions.



Analog Switches

Schematic Diagram (Typical Channel)

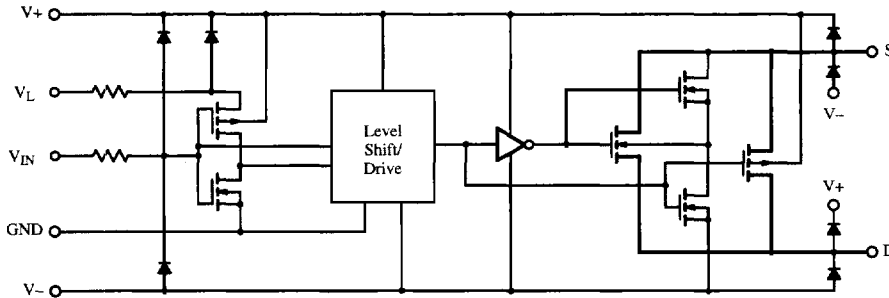
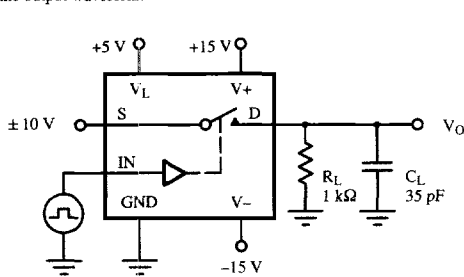

Figure 1.

Test Circuits

V_O is the steady state output with the switch on. Feedthrough via switch capacitance may result in spikes at the leading and trailing edge of the output waveform.



C_L (includes fixture and stray capacitance)

$$V_O = V_S \frac{R_L}{R_L + \tau_{DS(on)}}$$

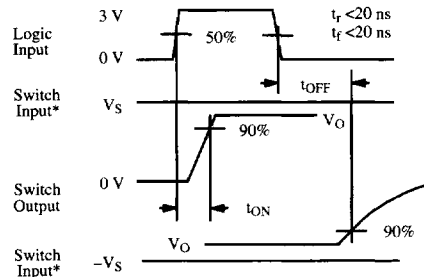

* $V_S = 10\text{ V}$ for t_{ON} . $V_S = -10\text{ V}$ for t_{OFF}

Note: Logic input waveform is inverted for switches that have the opposite logic sense control

Figure 2. Switching Time

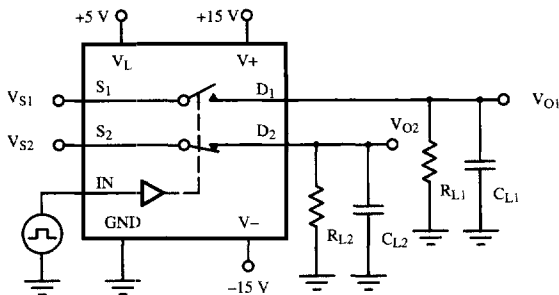

C_L (includes fixture and stray capacitance)

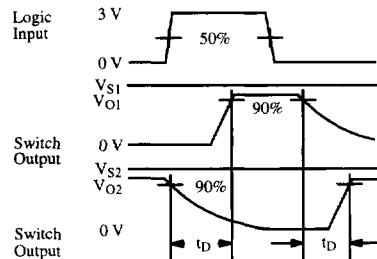

Figure 3. Break-Before-Make

Test Circuits (Cont'd)

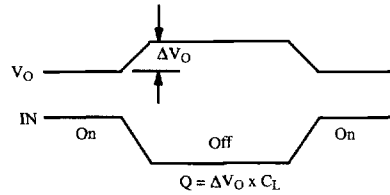
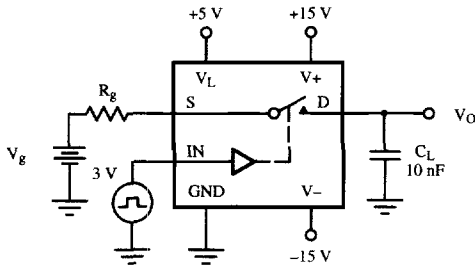

Figure 4. Charge Injection

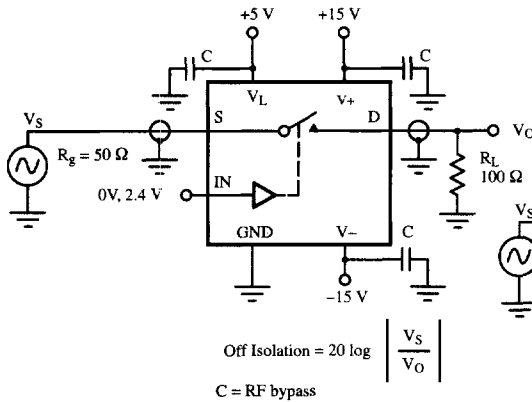

Figure 5. Off Isolation

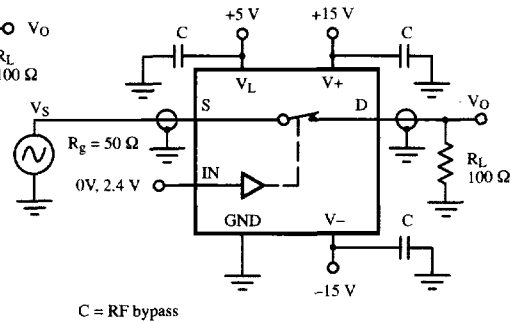

Figure 6. Insertion Loss

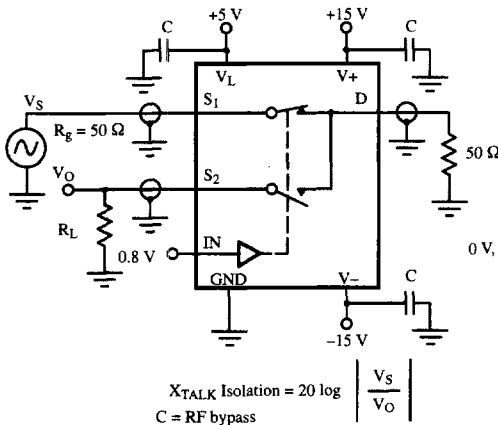

Figure 7. Crosstalk

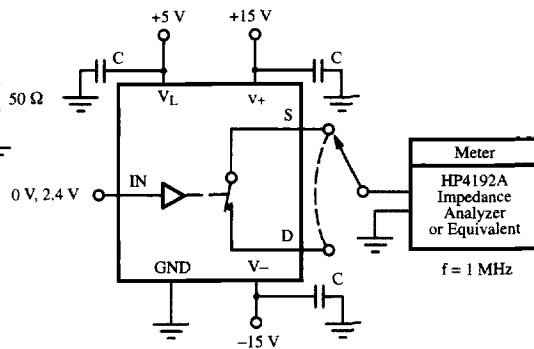

Figure 8. Capacitances

Analog Switches

Applications

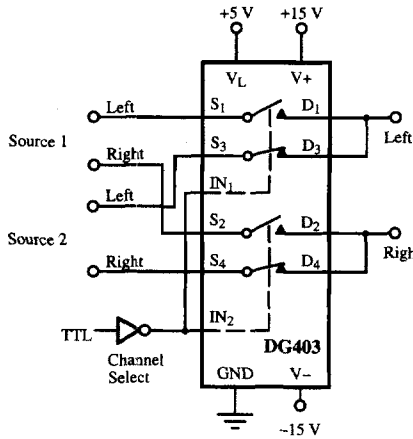

Figure 9. Stereo Source Selector

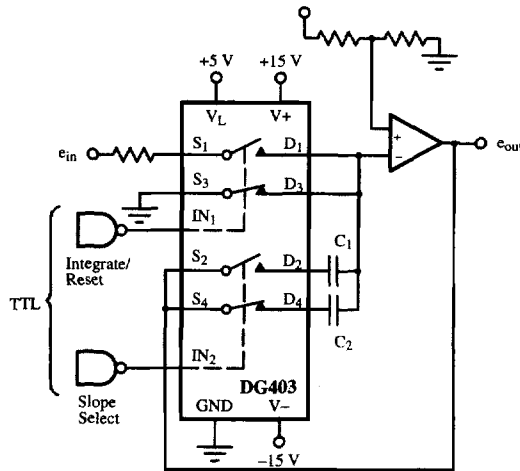

Figure 10. Dual Slope Integrator

Stereo Source Selector:

A single logic signal controls the status of all four switches of the device, simplifying stereo source switching. The low on-resistance ($<35 \Omega$) minimizes total harmonic distortion.

Dual Slope Integrators:

The DG403 is well suited to configure a selectable slope integrator. One control signal selects the timing capacitor C_1 or C_2 . Another one selects e_{in} or discharges the capacitor in preparation for the next integration cycle.

Band-Pass Switched Capacitor Filter:

Single-pole double-throw switches are a common element for switched capacitor networks and filters. The fast switching times and low leakage of the DG403 allow for higher clock rates and consequently higher filter operating frequencies.

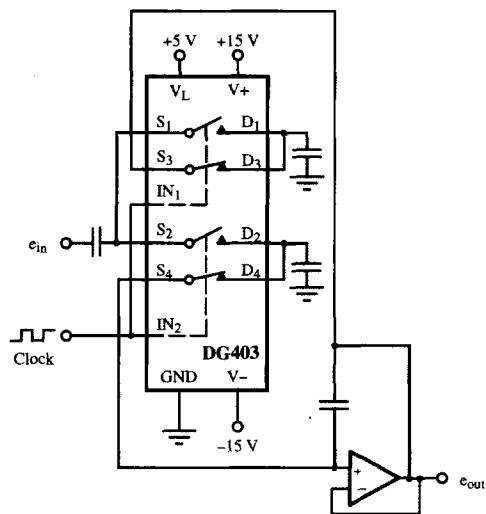

Figure 11. Band-Pass Switched Capacitor Filter

Applications (Cont'd)

Peak Detector:

A₃ acting as a comparator provides the logic drive for operating SW₁. The output of A₂ is fed back to A₃ and compared to the analog input e_{in}. If e_{in} > e_{out} the output of A₃ is high keeping SW₁ closed. This allows C₁ to

charge up to the analog input voltage. When e_{in} goes below e_{out} A₃ goes negative, turning SW₁ off. The system will therefore store the most positive analog input experienced.

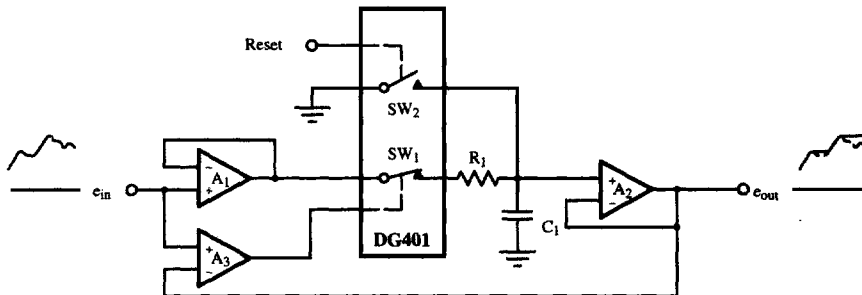

Figure 12. Positive Peak Detector



Analog Switches