



FEATURES:

- High reliability planar xmer design
- Ultra low ripple & noise
- No external capacitor required
- High power density
- High efficiencies to 90%
- Fully isolated to 1500Vdc
- 1.9" x 3.0" x 0.5" form factor
- -55 to +100°C operation available

Ordering Guide:

Model	Output					Input			Eff. (%) ⁴		Options					
	Vout (Volts)	Iout (A, max)	Power (Watt)	mVp-p ¹		Regulation ²		Vin	Range	Iin ³ (mA)		Eff. (%) ⁴				
				Ripple	Noise	Line	Load					min.	typ.			
GH50S1205	5.0	10	50	120	140	±0.2	±0.5	12	10-20	70	85	87	C, TS, DR			
GH50S2405								24	18-36	70	87	89				
GH50S4805								48	36-75	70	88	90				
GH50S24W05								24	10-36	70	87	89				
GH50S48W05								48	18-75	70	88	90				
GH100S1205								12	10-20	70	85	87				
GH100S2405		24	18-36	70	87			89								
GH100S4805		48	36-75	70	88			90								
GH100S24W05		24	10-36	70	87			89								
GH100S48W05		48	18-75	70	88			90								
GH50S1210		10	5.0	50	120			140	±0.2	±0.5	12	10-20		40	85	87
GH50S2410											24	18-36		40	85	87
GH50S4810	48					36-75	40				85	87				
GH50S24W10	24					10-36	40				85	87				
GH50S48W10	48					18-75	40				85	87				
GH100S1210	12					10-20	40				83	85				
GH100S2410	24		18-36	40	85	87										
GH100S4810	48		36-75	40	85	87										
GH100S24W10	24		10-36	40	85	87										
GH100S48W10	48		18-75	40	85	87										

...continue

Ordering Guide: (continued)

Model	Output					Input			Eff. (%) ⁴		Options				
	Vout (Volts)	Iout (A, max)	Power (Watt)	mVp-p ¹		Regulation ²		Vin	Range	Iin ³ (mA)		min.	typ.		
				Ripple	Noise	Line	Load								
GH50S1212	12	4.2	50	120	140	±0.2	±0.5	12	10-20	40	88	90	C, TS, DR		
GH50S2412								24	18-36	40	88	90			
GH50S4812								48	36-75	40	88	90			
GH50S24W12								24	10-36	40	88	90			
GH50S48W12								48	18-75	40	88	90			
GH100S1212		8.4	100	200	220			±0.2	±0.5	12	10-20	40		85	87
GH100S2412										24	18-36	40		86	88
GH100S4812										48	36-75	40		87	89
GH100S24W12										24	10-36	40		86	88
GH100S48W12										48	18-75	40		87	89
GH50S1215	15	3.4	50	120	140	±0.2	±0.5			12	10-20	40		87	89
GH50S2415										24	18-36	40		88	90
GH50S4815										48	36-75	40		88	90
GH50S24W15										24	10-36	40		88	90
GH50S48W15										48	18-75	40		88	90
GH100S1215		6.7	100	200	220			±0.2	±0.5	12	10-20	40		87	89
GH100S2415										24	18-36	40		88	90
GH100S4815										48	36-75	40		88	90
GH100S24W15										24	10-36	40		88	90
GH100S48W15										48	18-75	40		88	90
GH50S1224	24	2.1	50	120	140	±0.2	±0.5			12	10-20	40		88	90
GH50S2424										24	18-36	40		88	90
GH50S4824										48	36-75	40		88	90
GH50S24W24										24	10-36	40		88	90
GH50S48W24										48	18-75	40		88	90
GH100S1224		4.2	100	200	220			±0.2	±0.5	12	10-20	40		88	90
GH100S2424										24	18-36	40		88	90
GH100S4824										48	36-75	40		88	90
GH100S24W24										24	10-36	40	88	90	
GH100S48W24										48	18-75	40	88	90	
GH50S1228	28	1.8	50	120	140	±0.2	±0.5			12	10-20	40	88	90	
GH50S2428										24	18-36	40	88	90	
GH50S4828										48	36-75	40	88	90	
GH50S24W28										24	10-36	40	88	90	
GH50S48W28										48	18-75	40	88	90	
GH100S1228		3.6	100	200	220			±0.2	±0.5	12	10-20	40	86	88	
GH100S2428										24	18-36	40	88	90	
GH100S4828										48	36-75	40	88	90	
GH100S24W28										24	10-36	40	88	90	
GH100S48W28										48	18-75	40	88	90	

¹ Measured without external capacitor, 20MHz B.W.

² 5% to 100% load.

³ No load input current.

⁴ Nominal line voltage and full load.

BLOCK DIAGRAM: 5.0V

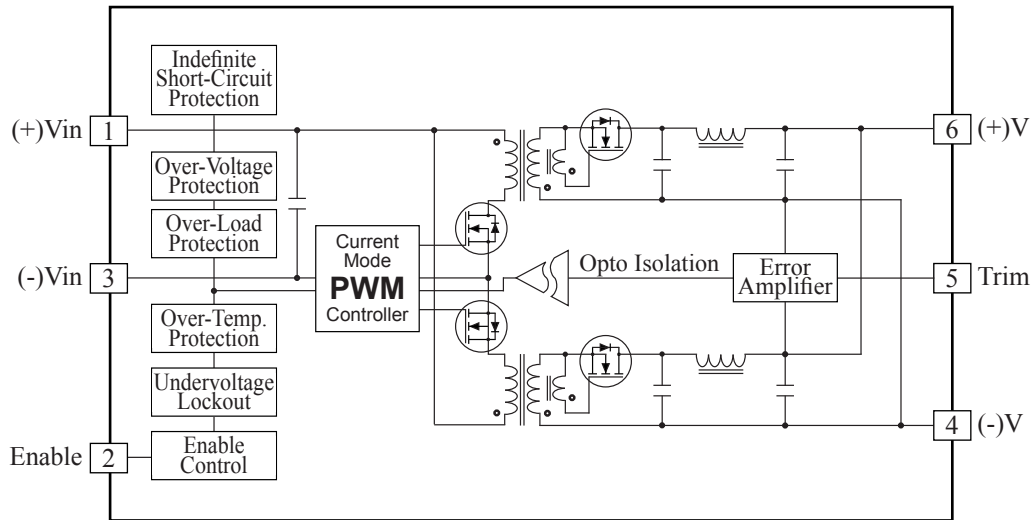

BLOCK DIAGRAM: 10V, 12V, 15V, 24V, 28V

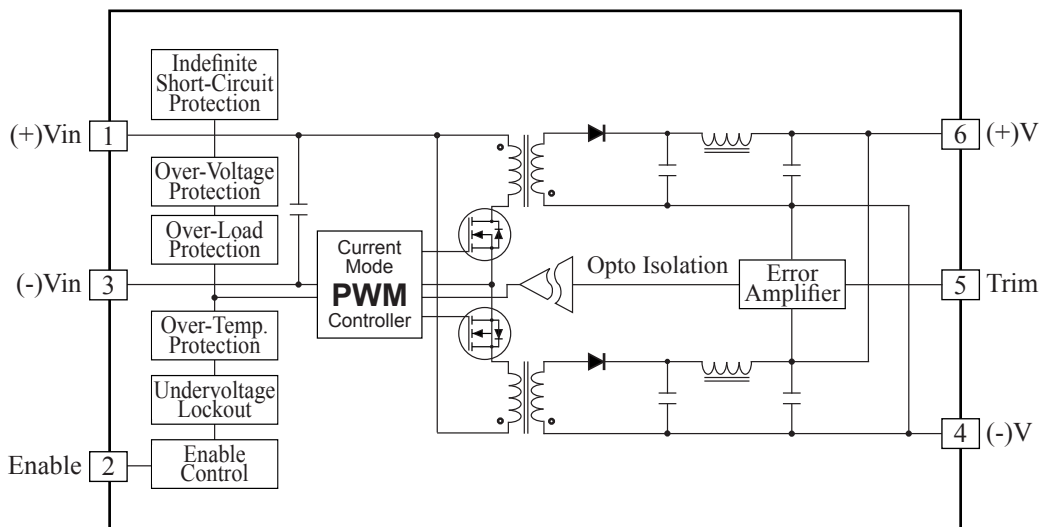

INPUT SPECIFICATIONS

All specifications apply over specified input voltage, output load, and temperature range, unless otherwise noted.

Model No./Parameter	Condition/Description	Min	Nom	Max	Units
GHxxS12xx (Vin = 10 - 20V)	Input Voltage Continuous	10	12	20	VDC
	Input Transient Withstand (100mSec)			30	VDC
	Input Over Voltage Protection		21		VDC
	Output ON (Input Ramping Up)	9.4		9.8	VDC
	Output OFF (Input Ramping Down)	9.2		9.4	VDC
GHxxS24xx (Vin = 18 - 36V)	Input Voltage Continuous	18	24	36	VDC
	Input Transient Withstand (100mSec)			50	VDC
	Input Over Voltage Protection		37		VDC
	Output ON (Input Ramping Up)	17.8		18	VDC
	Output OFF (Input Ramping Down)	17.2		17.6	VDC
GHxxS48xx (Vin = 36 - 75V)	Input Voltage Continuous	36	48	75	VDC
	Input Transient Withstand (100mSec)			100	VDC
	Input Over Voltage Protection		76		VDC
	Output ON (Input Ramping Up)	35.6		36	VDC
	Output OFF (Input Ramping Down)	35		35.6	VDC
GHxxS24Wxx (Vin = 10 - 36V)	Input Voltage Continuous	10	24	36	VDC
	Input Transient Withstand (100mSec)			50	VDC
	Input Over Voltage Protection		37		VDC
	Output ON (Input Ramping Up)	9.4		9.8	VDC
	Output OFF (Input Ramping Down)	9.2		9.4	VDC
GHxxS48Wxx (Vin = 18 - 75V)	Input Voltage Continuous	18	48	75	VDC
	Input Transient Withstand (100mSec)			100	VDC
	Input Over Voltage Protection		76		VDC
	Output ON (Input Ramping Up)	17.8		18	VDC
	Output OFF (Input Ramping Down)	17.2		17.6	VDC
Input Current	Disabled		8	10	mA
Enable Control (ON / OFF)	POSITIVE Enable Logic				
	POSITIVE Control ¹	+2.4		+18	VDC
	NEGATIVE Control	0		+1.8	VDC
	Source or Sink current			1.0	mA

¹Floating = POSITIVE Control

OUTPUT SPECIFICATIONS:

All specifications apply over specified input voltage, output load, and temperature range, unless otherwise noted.

Parameter	Condition/Description	Min	Nom	Max	Unit
Output Voltage	Vin ¹ = Nom, Iout ² = Max	4.95	5.00	5.05	VDC
Output Current	Baseplate Temperature =< +90 °C	0		10	A
Output Trim	Trim Up (Trim resistor to trim & -Vout pin)			5.50	VDC
	Trim Down (Trim resistor to trim & +Vout pin)	4.50			VDC
Line Regulation	Vin = Min to Max, Iout = Max			±0.2	%
Load Regulation	Vin = Nom, Iout = Min to Max			±0.5	%
Ripple & Noise (With no External Capacitor)	Ripple		20	30	mVp-p
	Spike (20MHz B.W.)		20	30	mVp-p
Transient Response: 75-100% step Load	Peak Deviation		±120	±160	mV
	Settling Time		100	120	µSec
Short Circuit Protection	Hiccup Mode Indefinite, Auto Recovery				
Output Over Voltage protection	Feedback Loop Voltage Clamp		6.5		VDC
Start-Up	Resistive Load		20	30	mSec

¹ Input Voltage.

² Output Current.

Output Ripple & Noise

(Measured with no external capacitor, 20MHz B.W.)

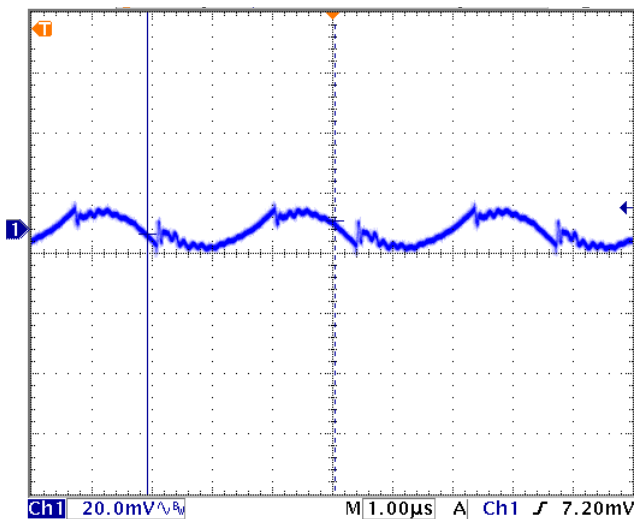

Output Load Transient

(75% to 100% Step Load change)

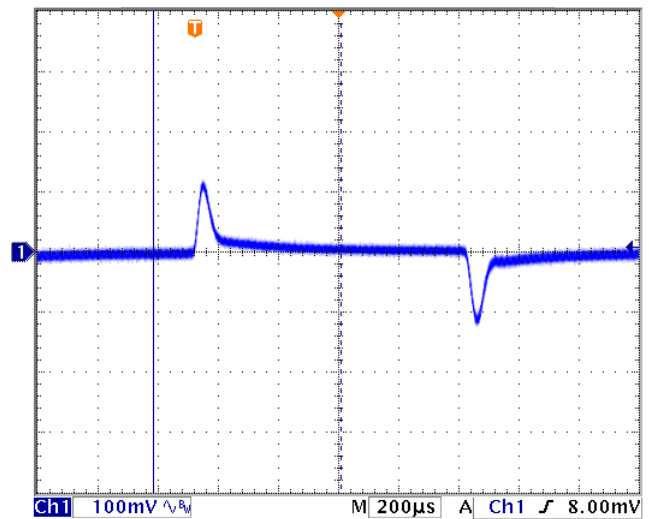

Start-Up

(Resistive, Full Load)

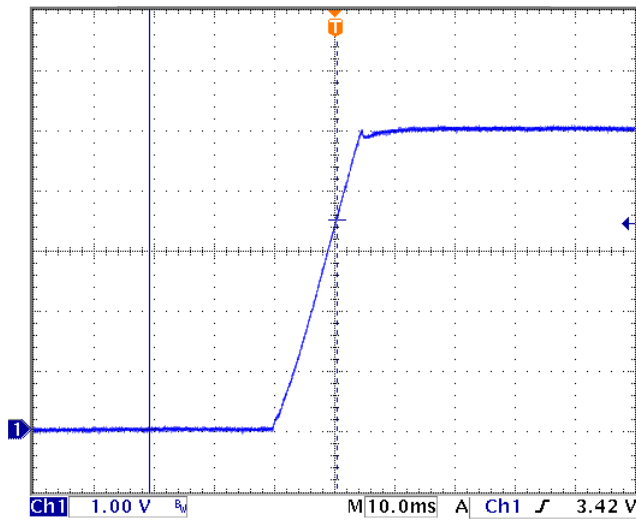

Efficiency Curves

(Measured @ Baseplate Temp < 50°C)

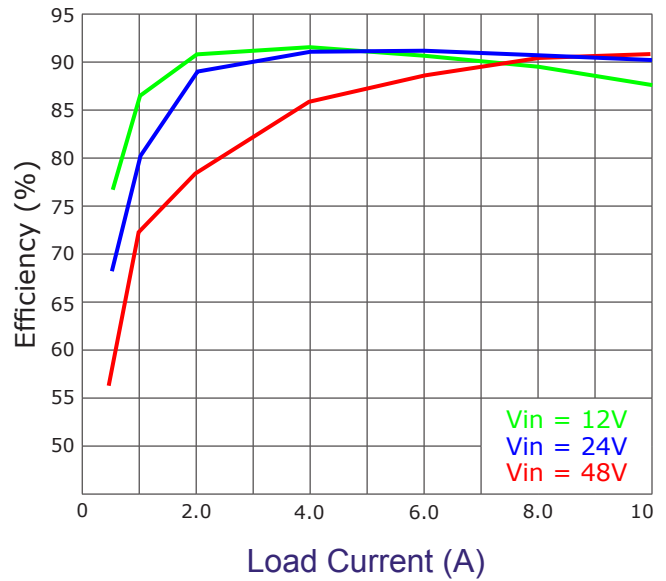

Output Voltage Trim

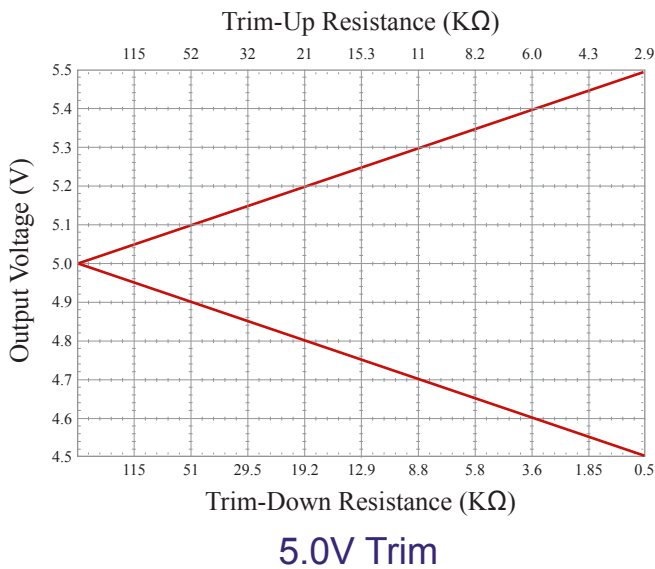

OUTPUT SPECIFICATIONS:

All specifications apply over specified input voltage, output load, and temperature range, unless otherwise noted.

Parameter	Condition/Description	Min	Nom	Max	Unit
Output Voltage	Vin ¹ = Nom, Iout ² = Max	4.95	5.00	5.05	VDC
Output Current	Baseplate Temperature =< +90 °C	0		20	A
Output Trim	Trim Up (Trim resistor to trim & -Vout pin)			5.50	VDC
	Trim Down (Trim resistor to trim & +Vout pin)	4.50			VDC
Line Regulation	Vin = Min to Max, Iout = Max			±0.2	%
Load Regulation	Vin = Nom, Iout = Min to Max			±0.5	%
Ripple & Noise (With no External Capacitor)	Ripple		10	20	mVp-p
	Spike (20MHz B.W.)		55	75	mVp-p
Transient Response: 75-100% step Load	Peak Deviation		±100	±120	mV
	Settling Time		100	120	µSec
Short Circuit Protection	Hiccup Mode Indefinite, Auto Recovery				
Output Over Voltage protection	Feedback Loop Voltage Clamp		6.5		VDC
Start-Up	Resistive Load		20	30	mSec

¹ Input Voltage.

² Output Current.

Output Ripple & Noise

(Measured with no external capacitor, 20MHz B.W.)

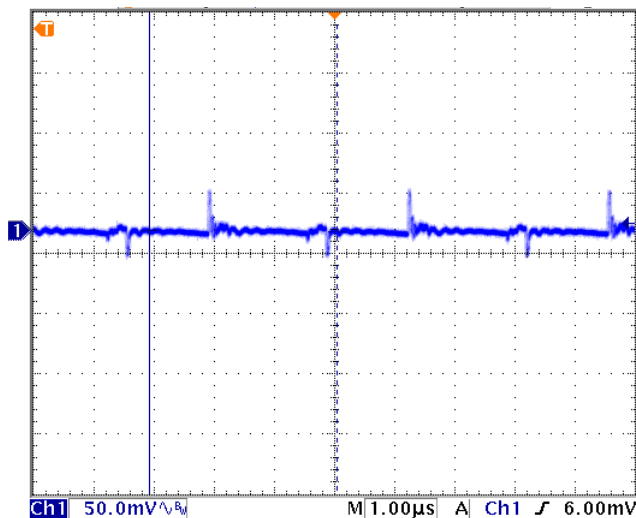

Output Load Transient

(75% to 100% Step Load change)

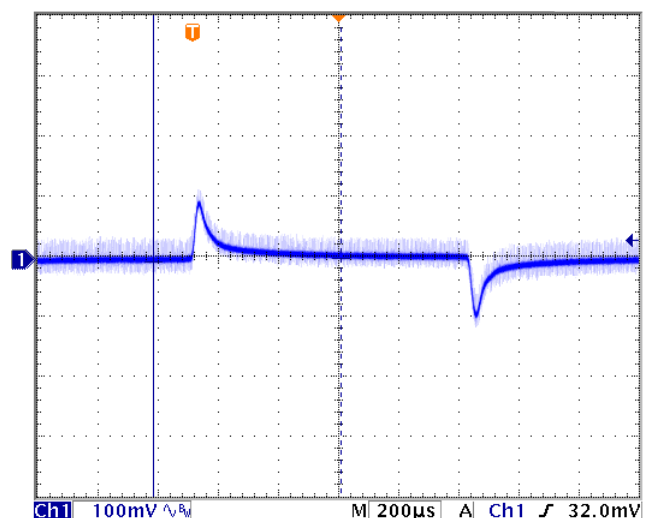

Start-Up

(Resistive, Full Load)

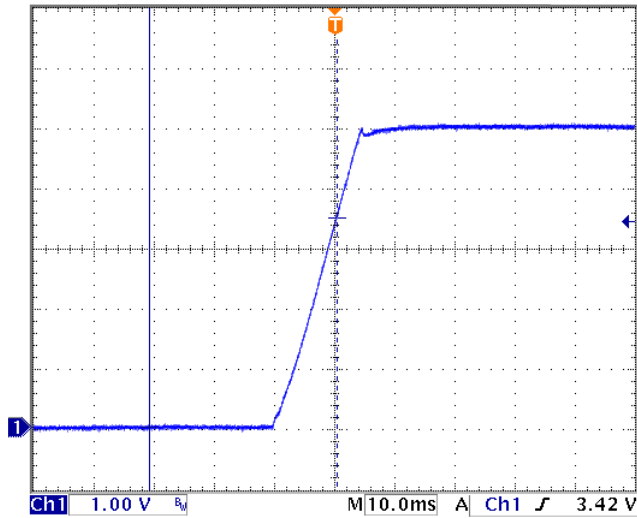

Efficiency Curves

(Measured @ Baseplate Temp < 50°C)

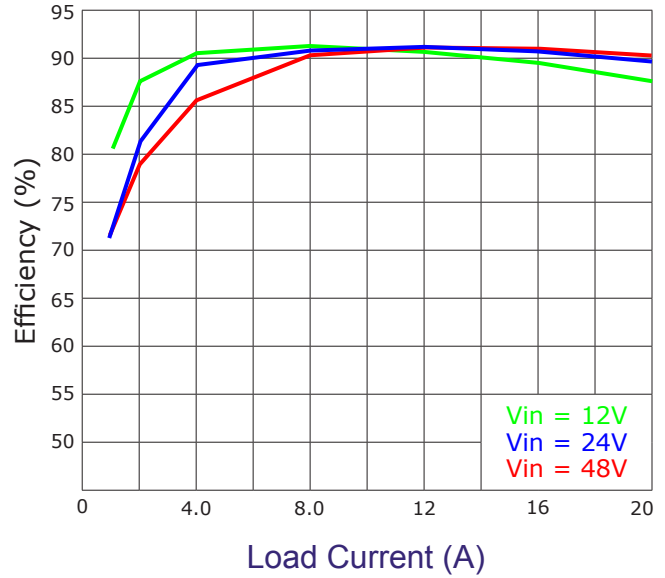

Output Voltage Trim

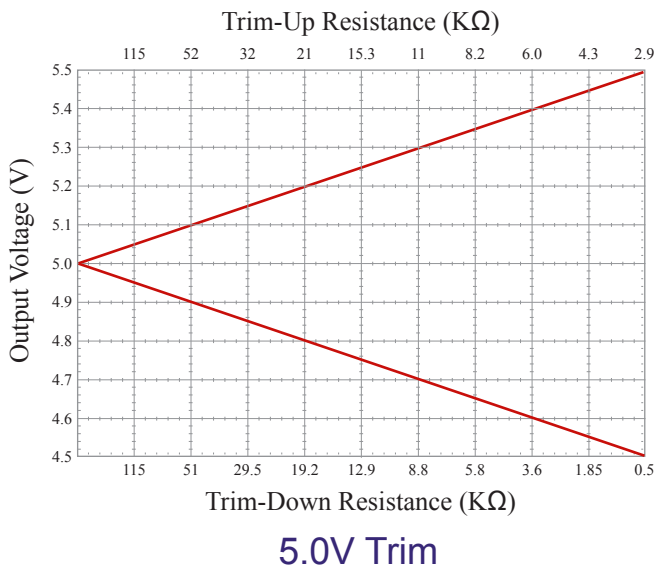

OUTPUT SPECIFICATIONS:

All specifications apply over specified input voltage, output load, and temperature range, unless otherwise noted.

Parameter	Condition/Description	Min	Nom	Max	Unit
Output Voltage	Vin ¹ = Nom, Iout ² = Max	9.0	10.0	11.0	VDC
Output Current	Baseplate Temperature =< +90 °C	0		5.0	A
Output Trim	Trim Up (Trim resistor to trim & -Vout pin)			11.0	VDC
	Trim Down (Trim resistor to trim & +Vout pin)	9.0			VDC
Line Regulation	Vin = Min to Max, Iout = Max			±0.2	%
Load Regulation	Vin = Nom, Iout = Min to Max			±0.5	%
Ripple & Noise (With no External Capacitor)	Ripple		80	100	mVp-p
	Spike (20MHz B.W.)		100	120	mVp-p
Transient Response: 75-100% step Load	Peak Deviation		±300	±340	mV
	Settling Time		120	150	µSec
Short Circuit Protection	Hiccup Mode Indefinite, Auto Recovery				
Output Over Voltage protection	Feedback Loop Voltage Clamp		13		VDC
Start-Up	Resistive Load		20	30	mSec

¹ Input Voltage.

² Output Current.

Output Ripple & Noise

(Measured with no external capacitor, 20MHz B.W.)

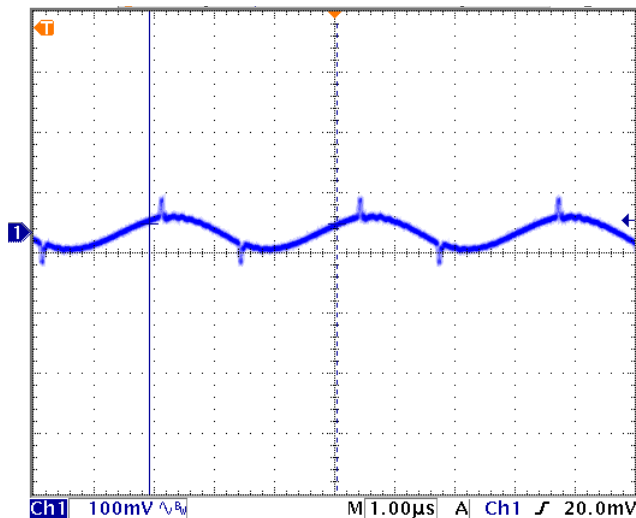

Output Load Transient

(75% to 100% Step Load change)

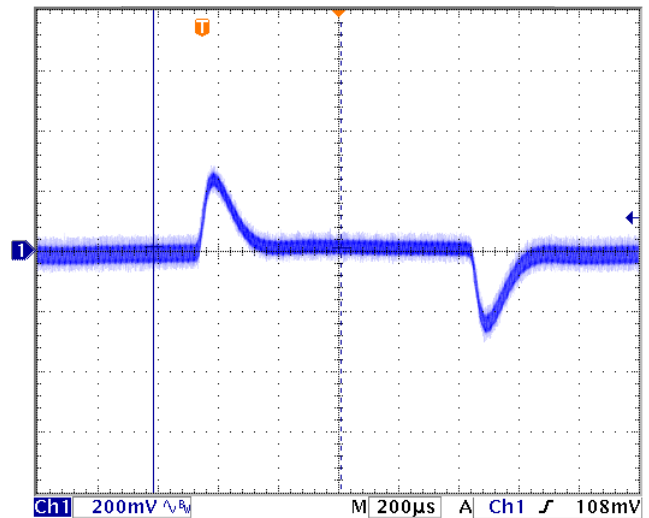

Start-Up

(Resistive, Full Load)

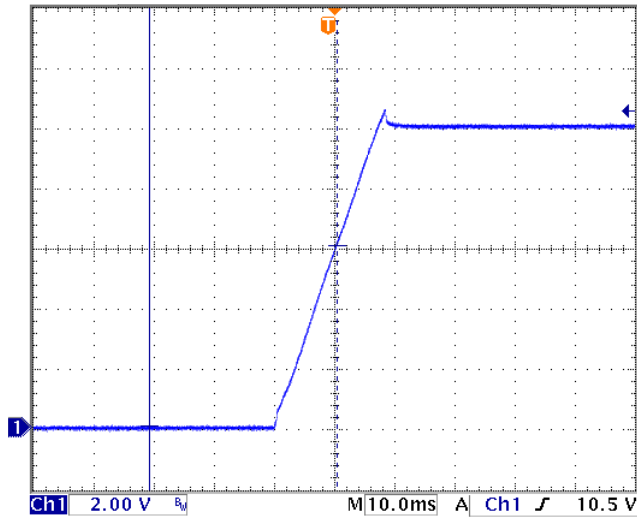

Efficiency Curves

(Measured @ Baseplate Temp < 50°C)

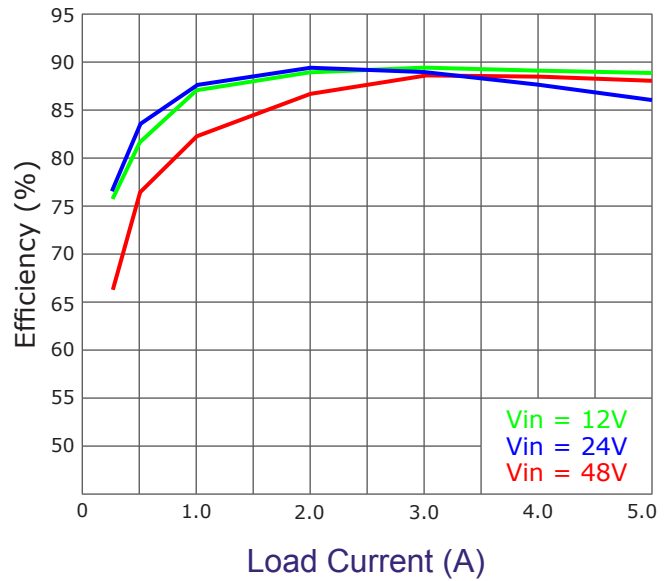

Output Voltage Trim



10V Trim

OUTPUT SPECIFICATIONS:

All specifications apply over specified input voltage, output load, and temperature range, unless otherwise noted.

Parameter	Condition/Description	Min	Nom	Max	Unit
Output Voltage	Vin ¹ = Nom, Iout ² = Max	9.0	10.0	11.0	VDC
Output Current	Baseplate Temperature =< +90 °C	0		10	A
Output Trim	Trim Up (Trim resistor to trim & -Vout pin)			11.0	VDC
	Trim Down (Trim resistor to trim & +Vout pin)	9.0			VDC
Line Regulation	Vin = Min to Max, Iout = Max			±0.2	%
Load Regulation	Vin = Nom, Iout = Min to Max			±0.5	%
Ripple & Noise (With no External Capacitor)	Ripple		20	30	mVp-p
	Spike (20MHz B.W.)		70	90	mVp-p
Transient Response: 75-100% step Load	Peak Deviation		±200	±240	mV
	Settling Time		150	200	µSec
Short Circuit Protection	Hiccup Mode Indefinite, Auto Recovery				
Output Over Voltage protection	Feedback Loop Voltage Clamp		13		VDC
Start-Up	Resistive Load		20	30	mSec

¹ Input Voltage.

² Output Current.

Output Ripple & Noise

(Measured with no external capacitor, 20MHz B.W.)

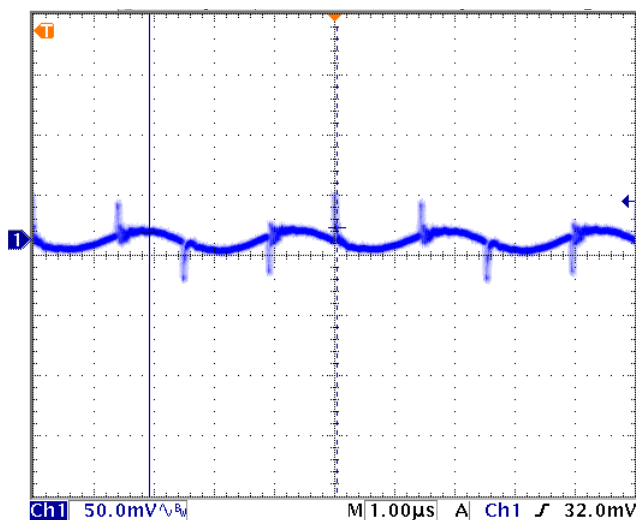

Output Load Transient

(75% to 100% Step Load change)

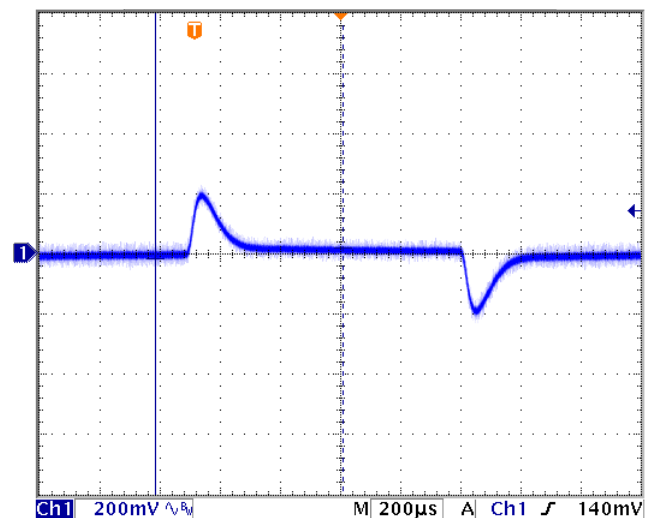

Start-Up

(Resistive, Full Load)

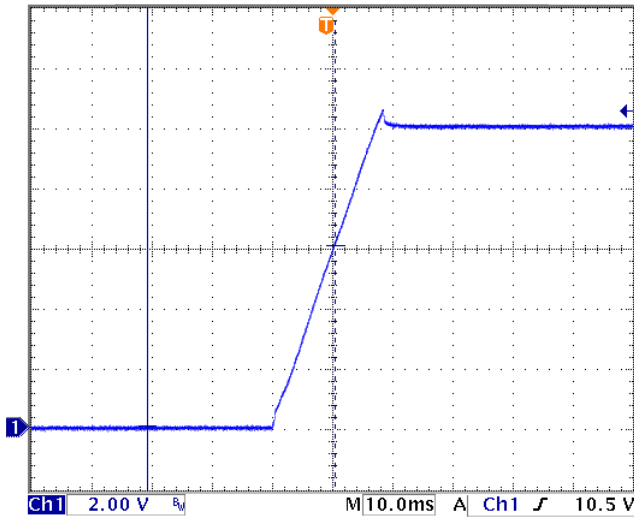

Efficiency Curves

(Measured @ Baseplate Temp < 50°C)

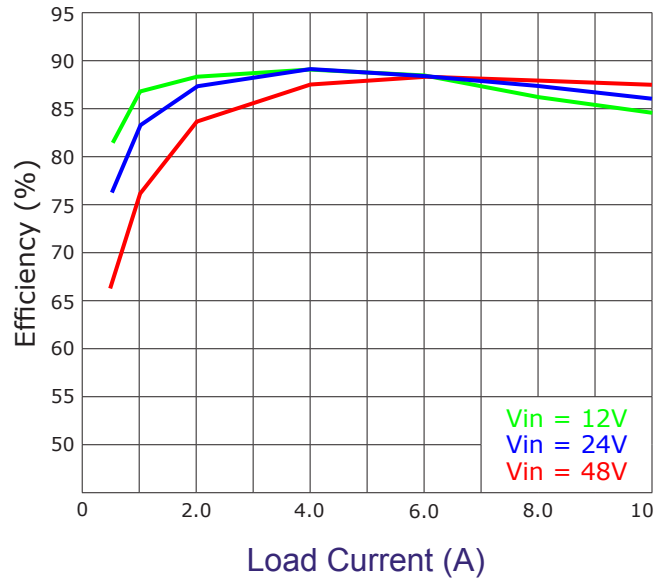

Output Voltage Trim

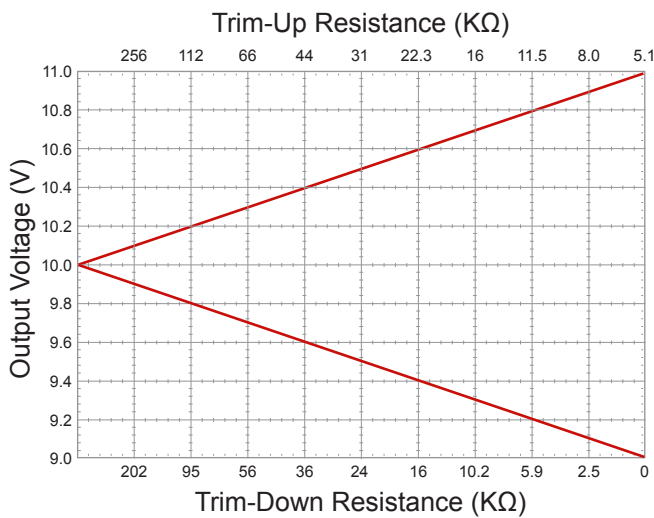

10V Trim

OUTPUT SPECIFICATIONS:

All specifications apply over specified input voltage, output load, and temperature range, unless otherwise noted.

Parameter	Condition/Description	Min	Nom	Max	Unit
Output Voltage	Vin ¹ = Nom, Iout ² = Max	11.88	12.00	12.12	VDC
Output Current	Baseplate Temperature =< +90 °C	0		4.2	A
Output Trim	Trim Up (Trim resistor to trim & -Vout pin)			13.2	VDC
	Trim Down (Trim resistor to trim & +Vout pin)	10.8			VDC
Line Regulation	Vin = Min to Max, Iout = Max			±0.2	%
Load Regulation	Vin = Nom, Iout = Min to Max			±0.5	%
Ripple & Noise (With no External Capacitor)	Ripple		80	100	mVp-p
	Spike (20MHz B.W.)		110	130	mVp-p
Transient Response: 75-100% step Load	Peak Deviation		±280	±320	mV
	Settling Time		150	200	µSec
Short Circuit Protection	Hiccup Mode Indefinite, Auto Recovery				
Output Over Voltage protection	Feedback Loop Voltage Clamp		15		VDC
Start-Up	Resistive Load		20	30	mSec

¹ Input Voltage.

² Output Current.

Output Ripple & Noise

(Measured with no external capacitor, 20MHz B.W.)

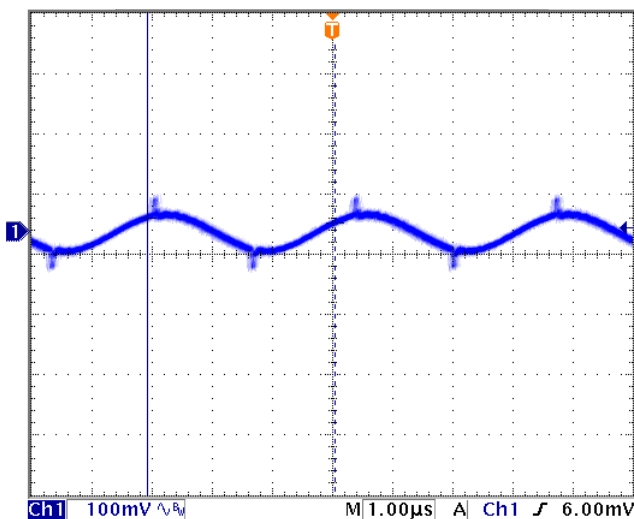

Output Load Transient

(75% to 100% Step Load change)

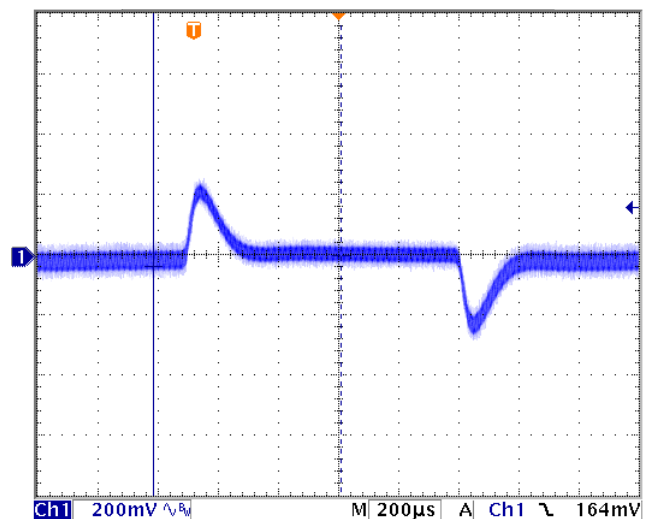

Start-Up

(Resistive, Full Load)

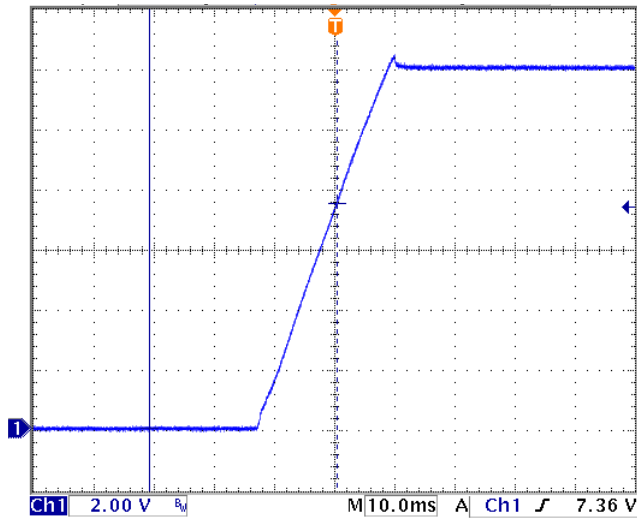

Efficiency Curves

(Measured @ Baseplate Temp < 50°C)

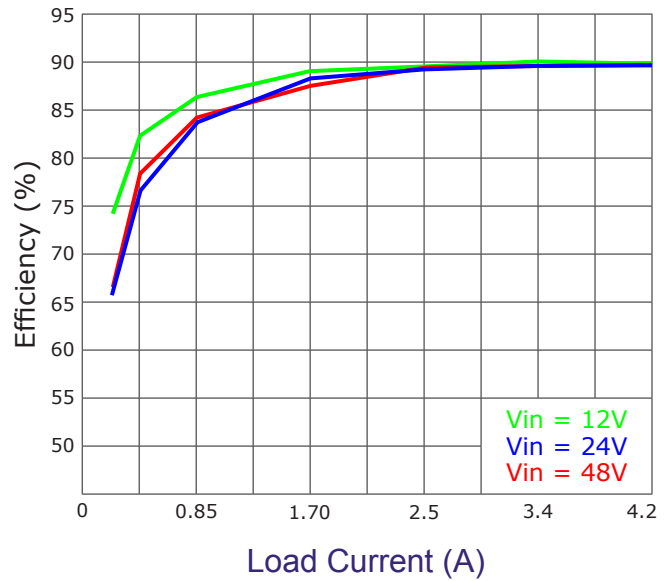

Output Voltage Trim

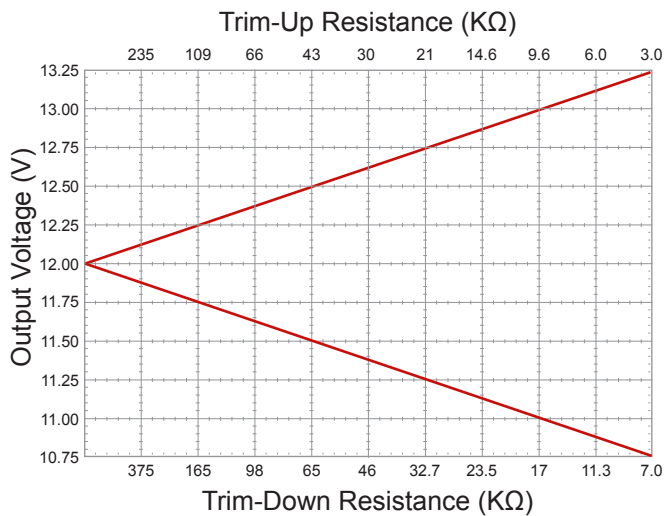

12V Trim

OUTPUT SPECIFICATIONS:

All specifications apply over specified input voltage, output load, and temperature range, unless otherwise noted.

Parameter	Condition/Description	Min	Nom	Max	Unit
Output Voltage	Vin ¹ = Nom, Iout ² = Max	11.88	12.00	12.12	VDC
Output Current	Baseplate Temperature =< +90 °C	0		8.4	A
Output Trim	Trim Up (Trim resistor to trim & -Vout pin)			13.2	VDC
	Trim Down (Trim resistor to trim & +Vout pin)	10.8			VDC
Line Regulation	Vin = Min to Max, Iout = Max			±0.2	%
Load Regulation	Vin = Nom, Iout = Min to Max			±0.5	%
Ripple & Noise (With no External Capacitor)	Ripple		30	50	mVp-p
	Spike (20MHz B.W.)		80	120	mVp-p
Transient Response: 75-100% step Load	Peak Deviation		±180	±220	mV
	Settling Time		150	200	µSec
Short Circuit Protection	Hiccup Mode Indefinite, Auto Recovery				
Output Over Voltage protection	Feedback Loop Voltage Clamp		15		VDC
Start-Up	Resistive Load		20	30	mSec

¹ Input Voltage.

² Output Current.

Output Ripple & Noise

(Measured with no external capacitor, 20MHz B.W.)

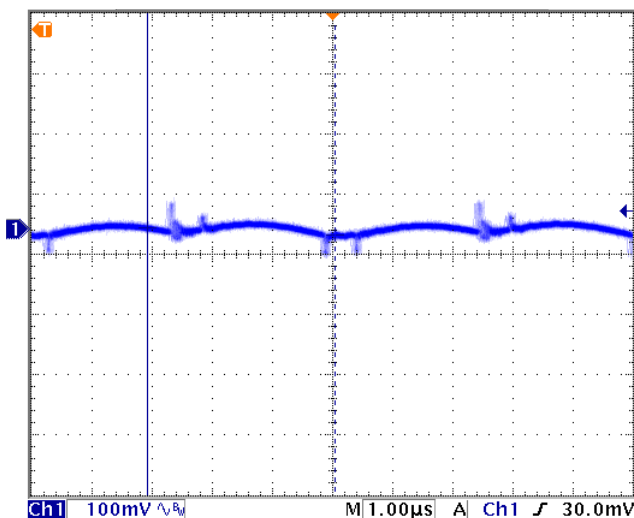

Output Load Transient

(75% to 100% Step Load change)

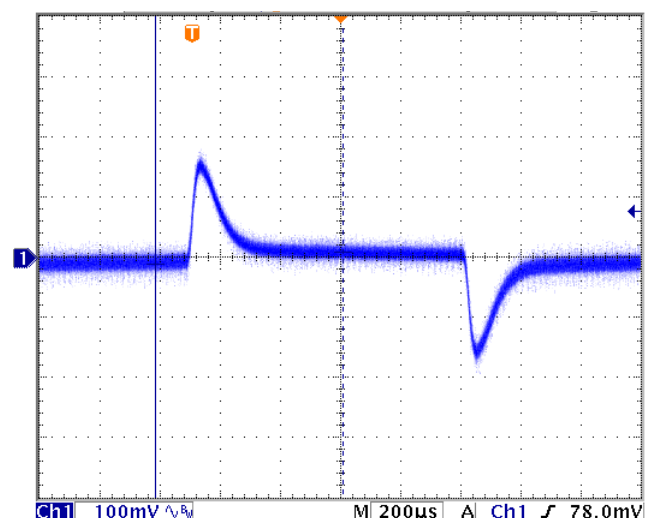

Start-Up

(Resistive, Full Load)

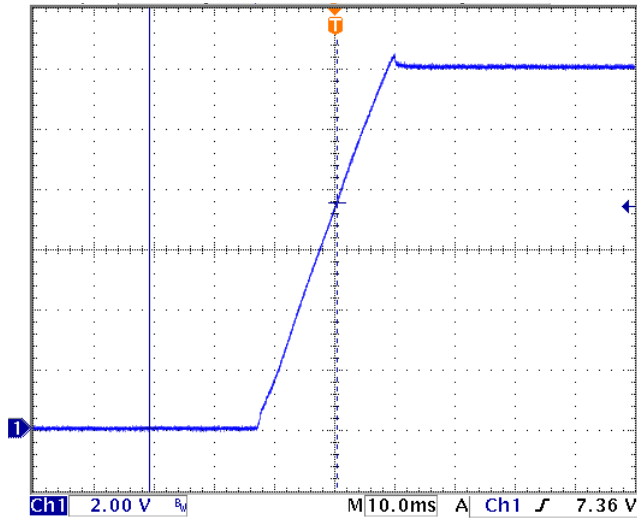

Efficiency Curves

(Measured @ Baseplate Temp < 50°C)

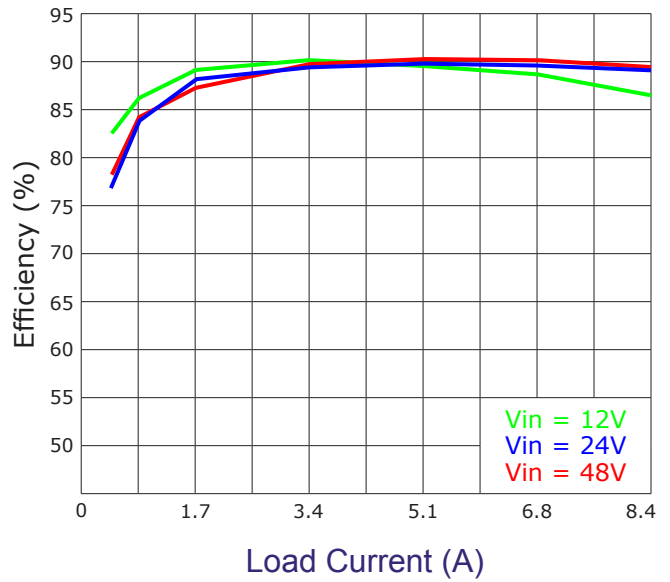

Output Voltage Trim

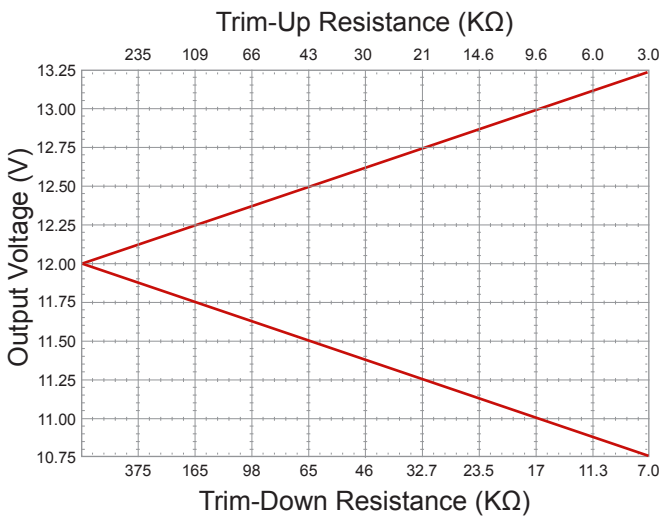

12V Trim

OUTPUT SPECIFICATIONS:

All specifications apply over specified input voltage, output load, and temperature range, unless otherwise noted.

Parameter	Condition/Description	Min	Nom	Max	Unit
Output Voltage	Vin ¹ = Nom, Iout ² = Max	14.85	15.00	15.15	VDC
Output Current	Baseplate Temperature =< +90 °C	0		3.4	A
Output Trim	Trim Up (Trim resistor to trim & -Vout pin)			16.5	VDC
	Trim Down (Trim resistor to trim & +Vout pin)	13.5			VDC
Line Regulation	Vin = Min to Max, Iout = Max			±0.2	%
Load Regulation	Vin = Nom, Iout = Min to Max			±0.5	%
Ripple & Noise (With no External Capacitor)	Ripple		80	100	mVp-p
	Spike (20MHz B.W.)		110	130	mVp-p
Transient Response: 75-100% step Load	Peak Deviation		±200	±240	mV
	Settling Time		120	200	µSec
Short Circuit Protection	Hiccup Mode Indefinite, Auto Recovery				
Output Over Voltage protection	Feedback Loop Voltage Clamp		19		VDC
Start-Up	Resistive Load		20	30	mSec

¹ Input Voltage.

² Output Current.

Output Ripple & Noise

(Measured with no external capacitor, 20MHz B.W.)

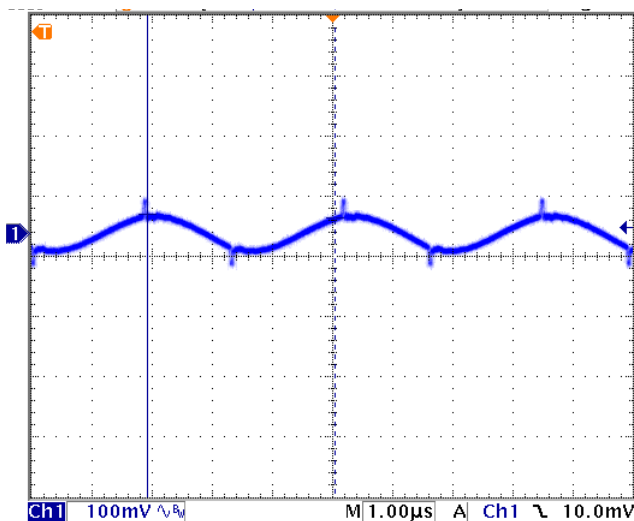

Output Load Transient

(75% to 100% Step Load change)

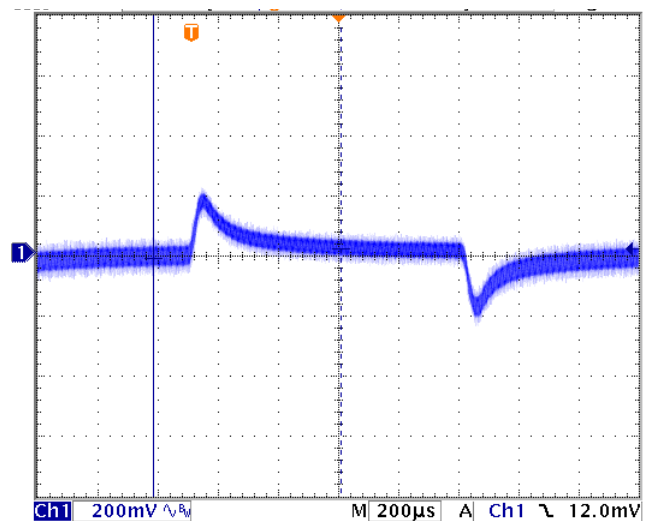

Start-Up

(Resistive, Full Load)

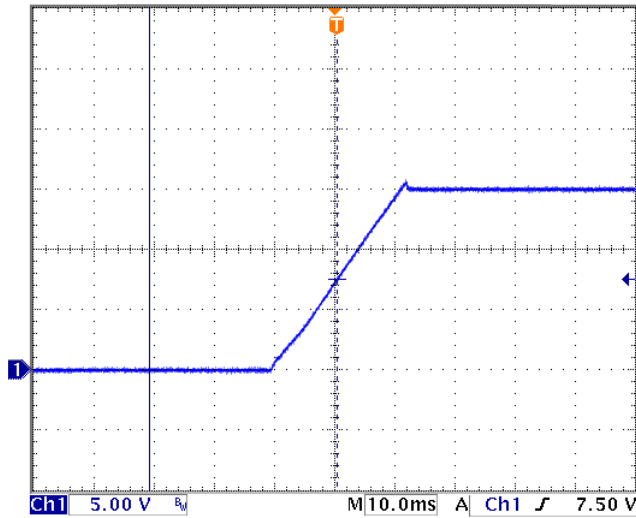

Efficiency Curves

(Measured @ Baseplate Temp < 50°C)

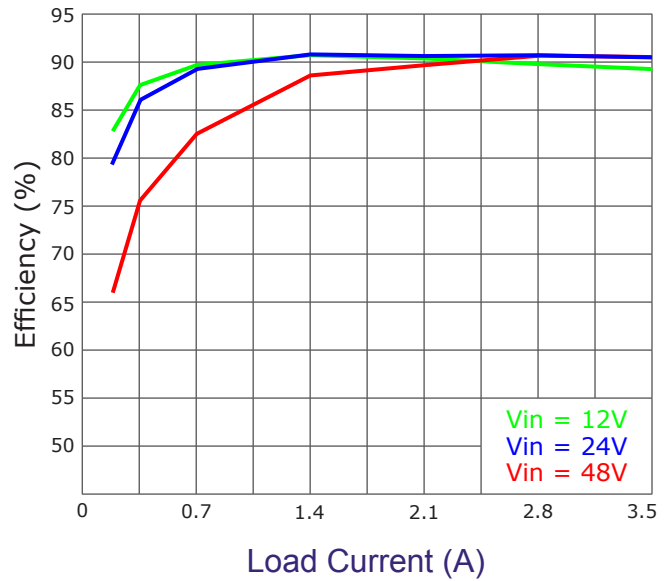

Output Voltage Trim

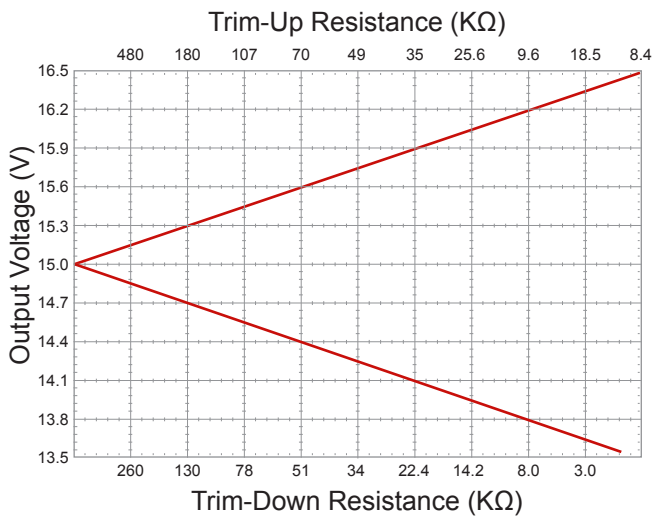

15V Trim

OUTPUT SPECIFICATIONS:

All specifications apply over specified input voltage, output load, and temperature range, unless otherwise noted.

Parameter	Condition/Description	Min	Nom	Max	Unit
Output Voltage	Vin ¹ = Nom, Iout ² = Max	14.85	15.00	15.15	VDC
Output Current	Baseplate Temperature =< +90 °C	0		6.7	A
Output Trim	Trim Up (Trim resistor to trim & -Vout pin)			16.5	VDC
	Trim Down (Trim resistor to trim & +Vout pin)	13.5			VDC
Line Regulation	Vin = Min to Max, Iout = Max			±0.2	%
Load Regulation	Vin = Nom, Iout = Min to Max			±0.5	%
Ripple & Noise (With no External Capacitor)	Ripple		30	50	mVp-p
	Spike (20MHz B.W.)		55	75	mVp-p
Transient Response: 75-100% step Load	Peak Deviation		±200	±240	mV
	Settling Time		120	200	µSec
Short Circuit Protection	Hiccup Mode Indefinite, Auto Recovery				
Output Over Voltage protection	Feedback Loop Voltage Clamp		19		VDC
Start-Up	Resistive Load		20	30	mSec

¹ Input Voltage.

² Output Current.

Output Ripple & Noise

(Measured with no external capacitor, 20MHz B.W.)

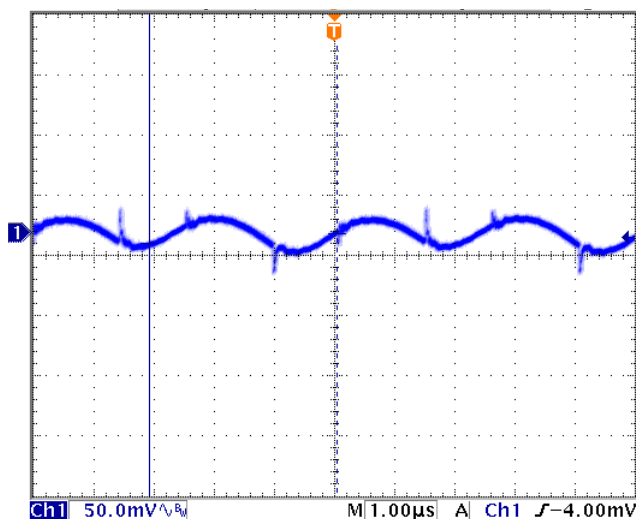

Output Load Transient

(75% to 100% Step Load change)

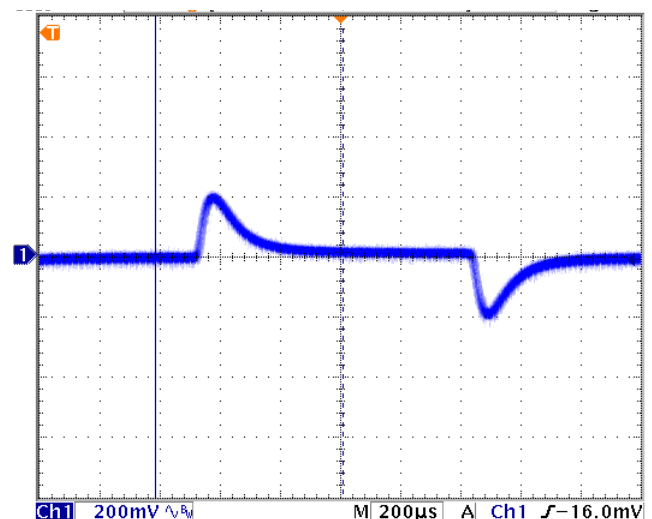

Start-Up

(Resistive, Full Load)

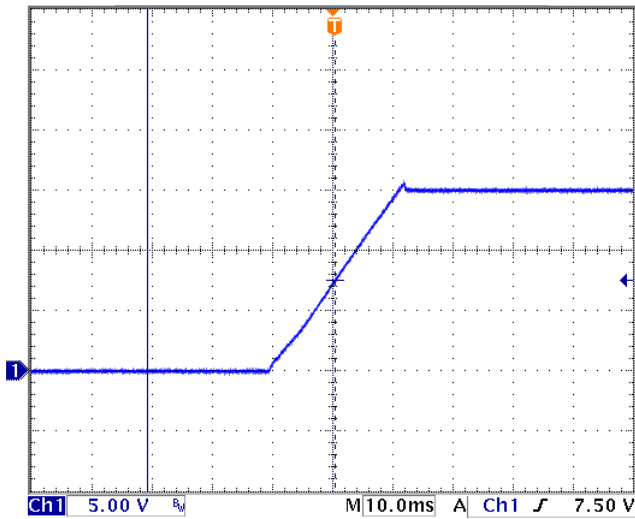

Efficiency Curves

(Measured @ Baseplate Temp < 50°C)

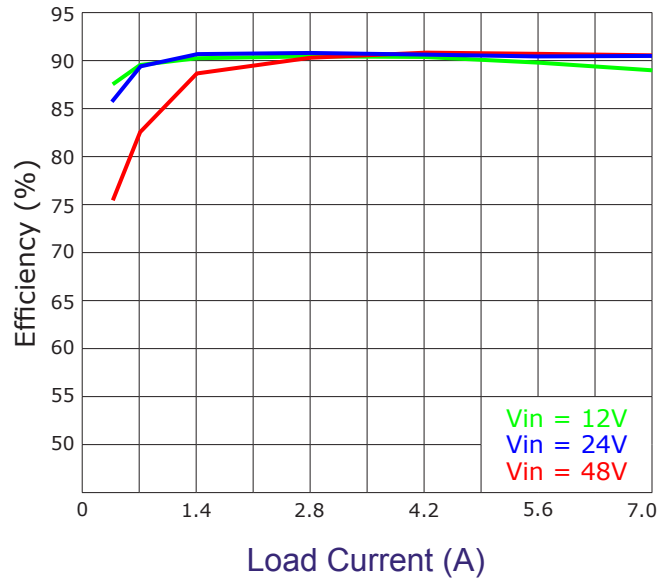

Output Voltage Trim



15V Trim

OUTPUT SPECIFICATIONS:

All specifications apply over specified input voltage, output load, and temperature range, unless otherwise noted.

Parameter	Condition/Description	Min	Nom	Max	Unit
Output Voltage	Vin ¹ = Nom, Iout ² = Max	23.76	24.0	24.24	VDC
Output Current	Baseplate Temperature =< +90 °C	0		2.1	A
Output Trim	Trim Up (Trim resistor to trim & -Vout pin)			26.4	VDC
	Trim Down (Trim resistor to trim & +Vout pin)	21.6			VDC
Line Regulation	Vin = Min to Max, Iout = Max			±0.2	%
Load Regulation	Vin = Nom, Iout = Min to Max			±0.5	%
Ripple & Noise (With no External Capacitor)	Ripple		80	100	mVp-p
	Spike (20MHz B.W.)		100	120	mVp-p
Transient Response: 75-100% step Load	Peak Deviation		±280	±320	mV
	Settling Time		100	200	µSec
Short Circuit Protection	Hiccup Mode Indefinite, Auto Recovery				
Output Over Voltage protection	Feedback Loop Voltage Clamp		31		VDC
Start-Up	Resistive Load		20	30	mSec

¹ Input Voltage.

² Output Current.

Output Ripple & Noise

(Measured with no external capacitor, 20MHz B.W.)

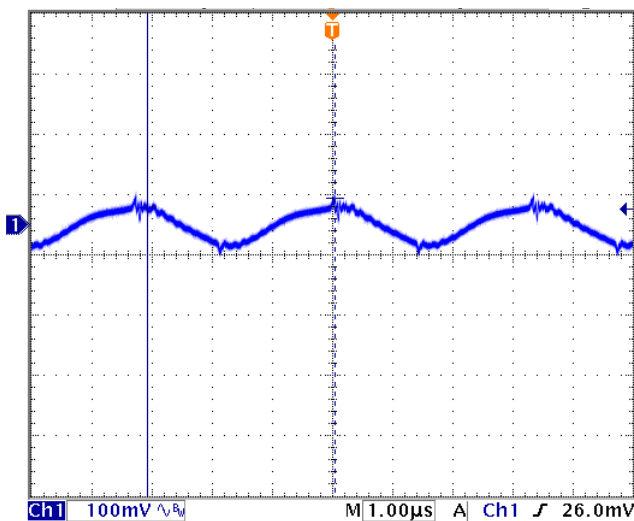

Output Load Transient

(75% to 100% Step Load change)

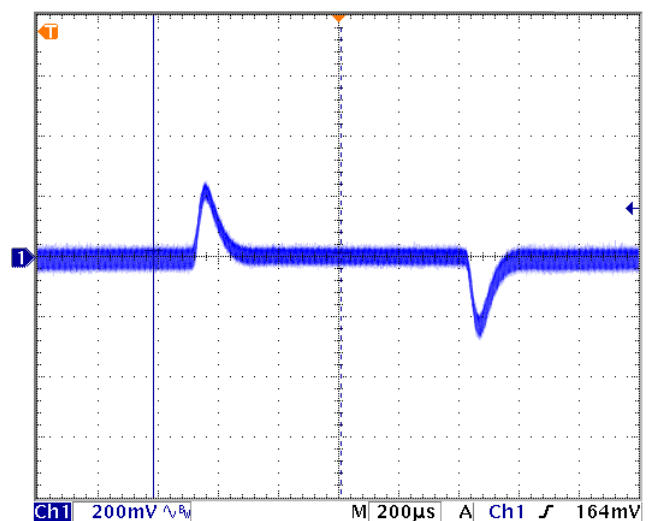

Start-Up

(Resistive, Full Load)

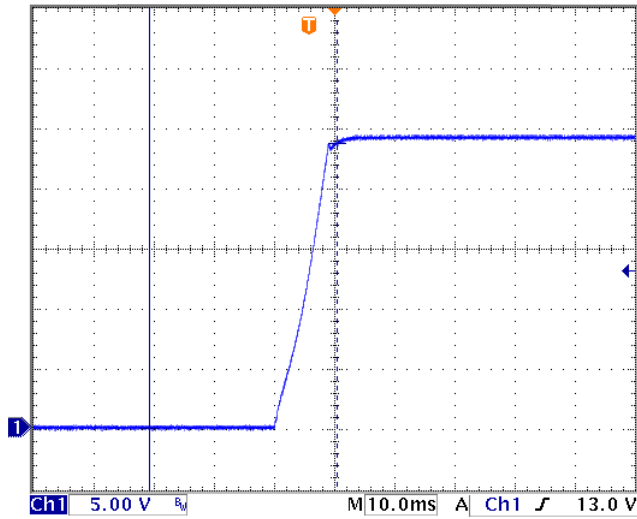

Efficiency Curves

(Measured @ Baseplate Temp < 50°C)

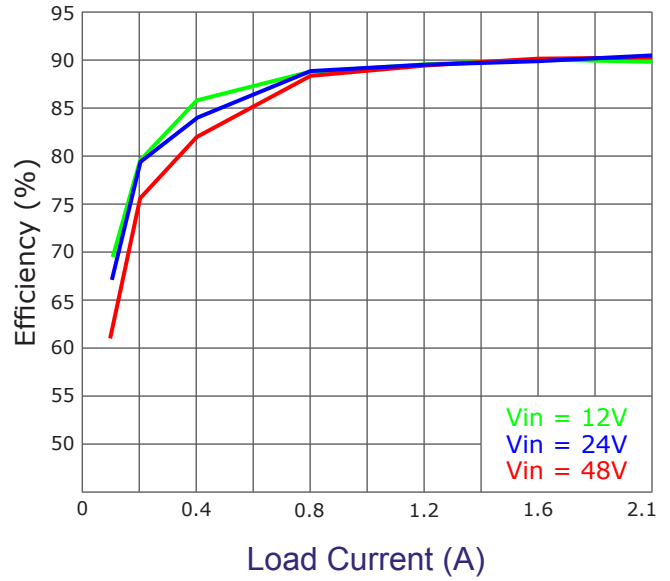

Output Voltage Trim

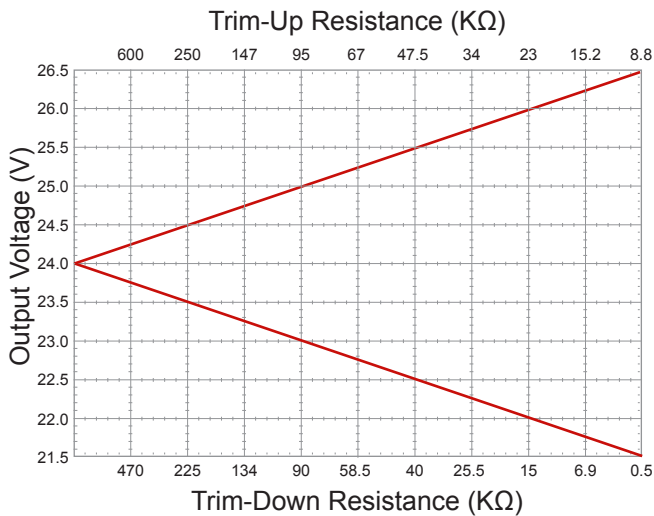

24V Trim

OUTPUT SPECIFICATIONS:

All specifications apply over specified input voltage, output load, and temperature range, unless otherwise noted.

Parameter	Condition/Description	Min	Nom	Max	Unit
Output Voltage	Vin ¹ = Nom, Iout ² = Max	23.76	24.0	24.24	VDC
Output Current	Baseplate Temperature =< +90 °C	0		4.2	A
Output Trim	Trim Up (Trim resistor to trim & -Vout pin)			26.4	VDC
	Trim Down (Trim resistor to trim & +Vout pin)	21.6			VDC
Line Regulation	Vin = Min to Max, Iout = Max			±0.2	%
Load Regulation	Vin = Nom, Iout = Min to Max			±0.5	%
Ripple & Noise (With no External Capacitor)	Ripple		40	60	mVp-p
	Spike (20MHz B.W.)		55	80	mVp-p
Transient Response: 75-100% step Load	Peak Deviation		±160	±200	mV
	Settling Time		100	150	µSec
Short Circuit Protection	Hiccup Mode Indefinite, Auto Recovery				
Output Over Voltage protection	Feedback Loop Voltage Clamp		31		VDC
Start-Up	Resistive Load		20	30	mSec

¹ Input Voltage.

² Output Current.

Output Ripple & Noise

(Measured with no external capacitor, 20MHz B.W.)

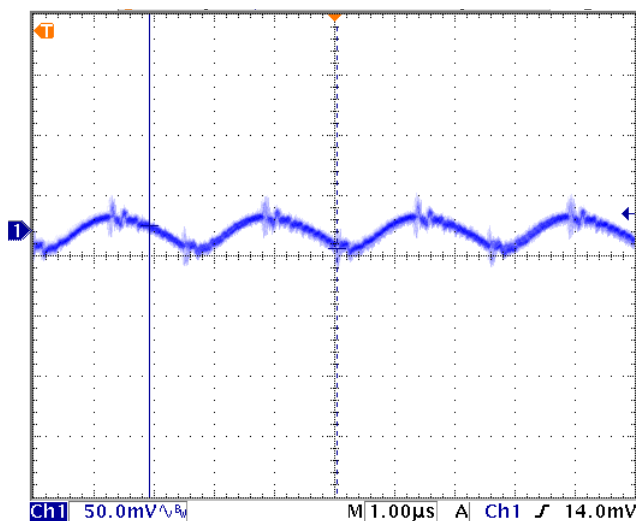

Output Load Transient

(75% to 100% Step Load change)

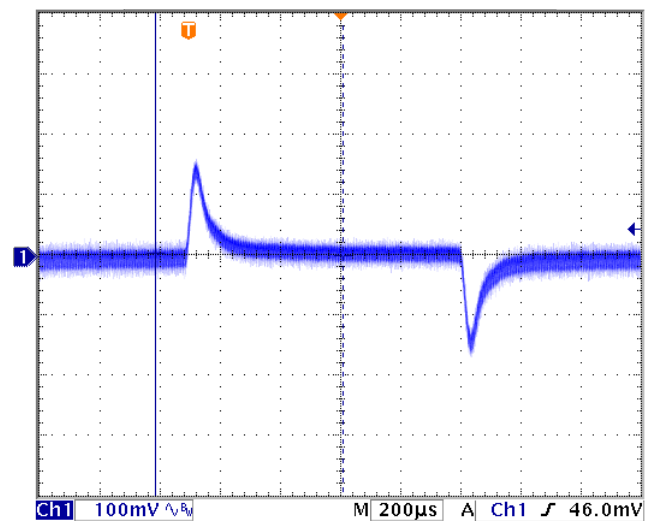

Start-Up

(Resistive, Full Load)

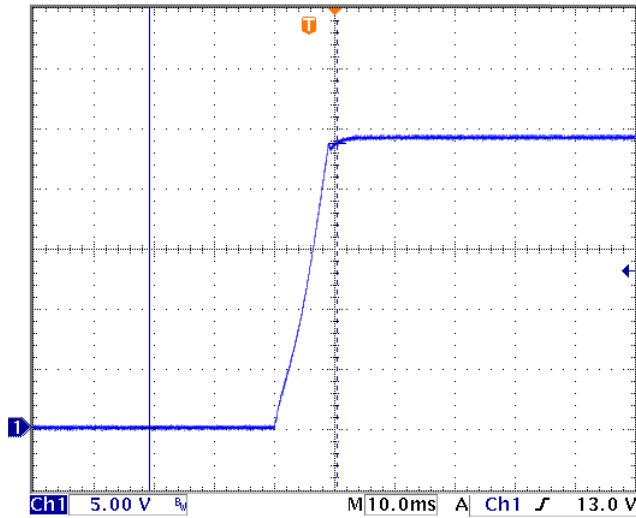

Efficiency Curves

(Measured @ Baseplate Temp < 50°C)

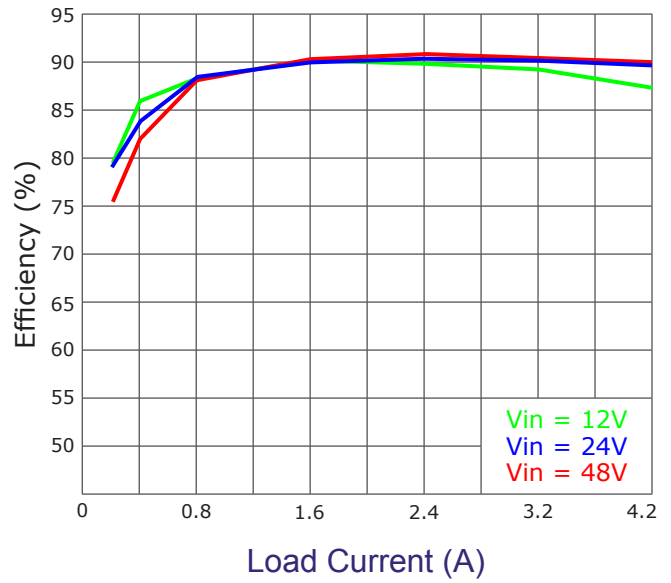

Output Voltage Trim

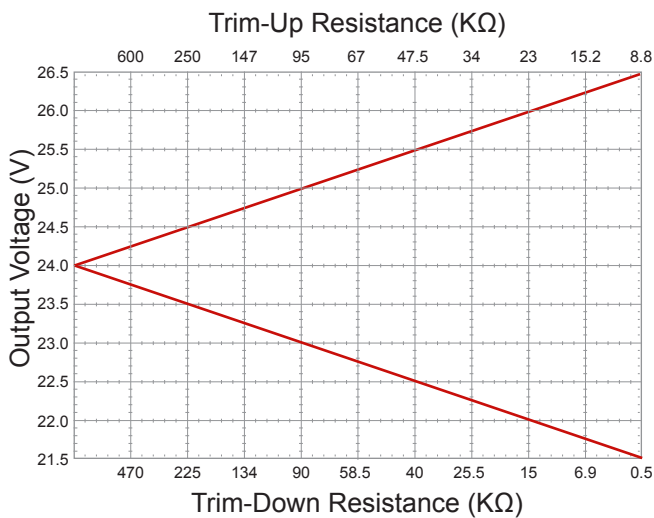

24V Trim

OUTPUT SPECIFICATIONS:

All specifications apply over specified input voltage, output load, and temperature range, unless otherwise noted.

Parameter	Condition/Description	Min	Nom	Max	Unit
Output Voltage	Vin ¹ = Nom, Iout ² = Max	27.72	28.0	28.28	VDC
Output Current	Baseplate Temperature =< +90 °C	0		1.8	A
Output Trim	Trim Up (Trim resistor to trim & -Vout pin)			30.8	VDC
	Trim Down (Trim resistor to trim & +Vout pin)	25.2			VDC
Line Regulation	Vin = Min to Max, Iout = Max			±0.2	%
Load Regulation	Vin = Nom, Iout = Min to Max			±0.5	%
Ripple & Noise (With no External Capacitor)	Ripple		90	120	mVp-p
	Spike (20MHz B.W.)		100	130	mVp-p
Transient Response: 75-100% step Load	Peak Deviation		±250	±300	mV
	Settling Time		100	150	µSec
Short Circuit Protection	Hiccup Mode Indefinite, Auto Recovery				
Output Over Voltage protection	Feedback Loop Voltage Clamp		36		VDC
Start-Up	Resistive Load		20	30	mSec

¹ Input Voltage.

² Output Current.

Output Ripple & Noise

(Measured with no external capacitor, 20MHz B.W.)

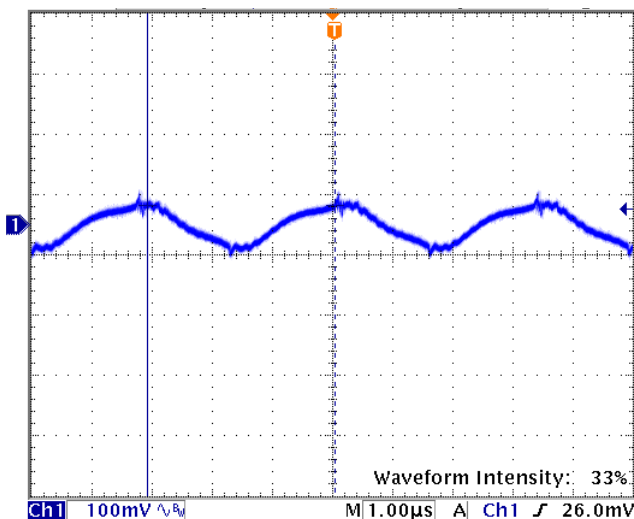

Output Load Transient

(75% to 100% Step Load change)

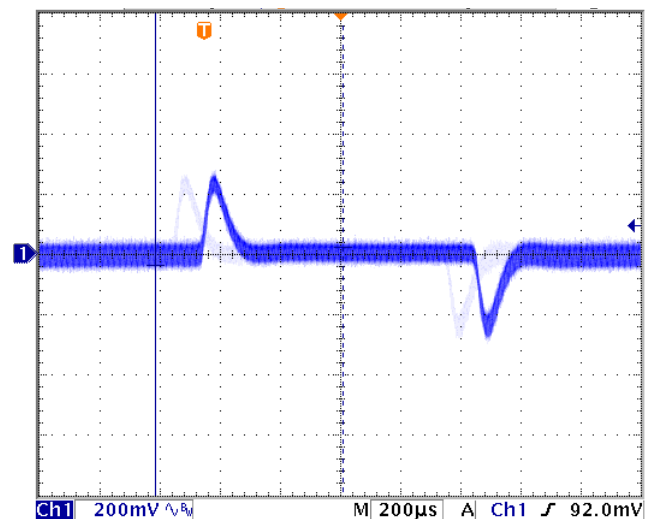

Start-Up

(Resistive, Full Load)

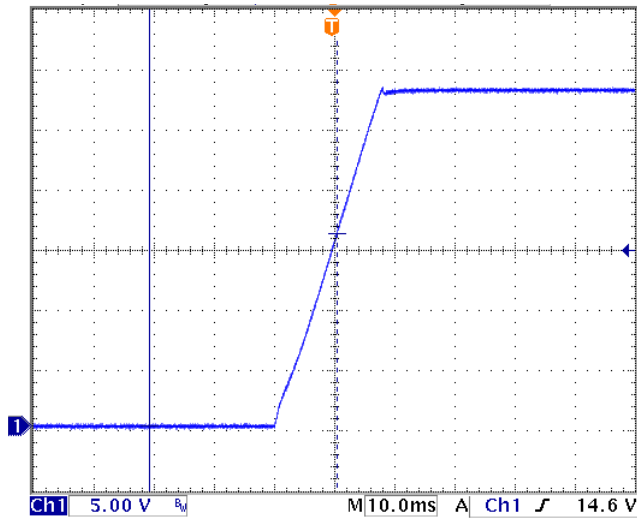

Efficiency Curves

(Measured @ Baseplate Temp < 50°C)

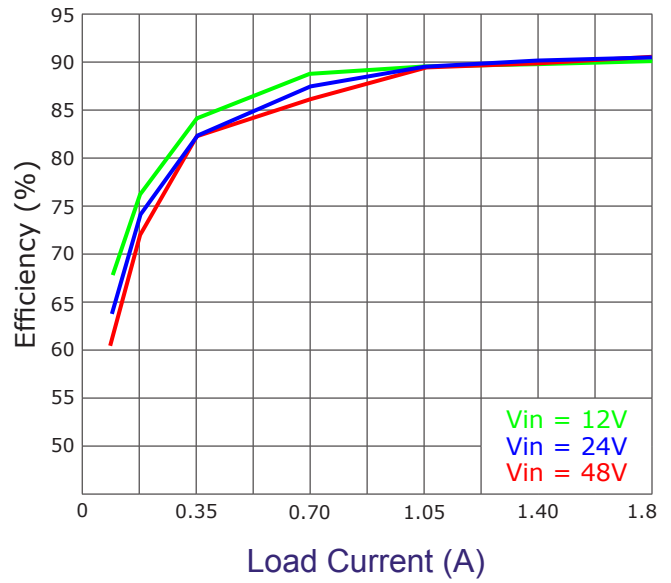

Output Voltage Trim

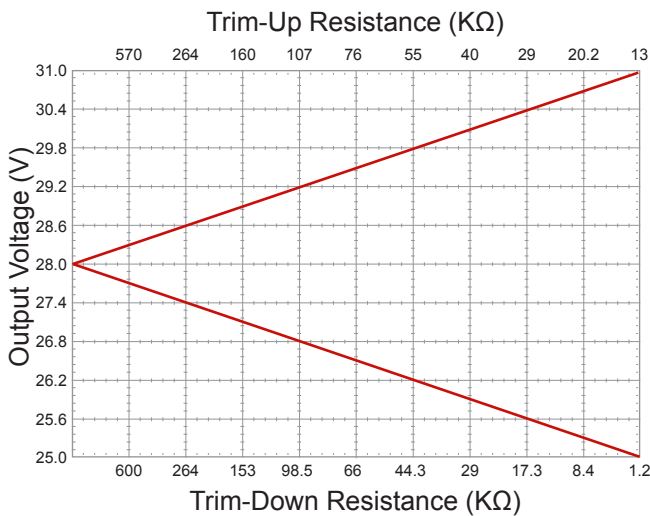

28V Trim

OUTPUT SPECIFICATIONS:

All specifications apply over specified input voltage, output load, and temperature range, unless otherwise noted.

Parameter	Condition/Description	Min	Nom	Max	Unit
Output Voltage	Vin ¹ = Nom, Iout ² = Max	27.72	28.0	28.28	VDC
Output Current	Baseplate Temperature =< +90 °C	0		3.6	A
Output Trim	Trim Up (Trim resistor to trim & -Vout pin)			30.8	VDC
	Trim Down (Trim resistor to trim & +Vout pin)	25.2			VDC
Line Regulation	Vin = Min to Max, Iout = Max			±0.2	%
Load Regulation	Vin = Nom, Iout = Min to Max			±0.5	%
Ripple & Noise (With no External Capacitor)	Ripple		30	50	mVp-p
	Spike (20MHz B.W.)		50	70	mVp-p
Transient Response: 75-100% step Load	Peak Deviation		±240	±300	mV
	Settling Time		100	150	µSec
Short Circuit Protection	Hiccup Mode Indefinite, Auto Recovery				
Output Over Voltage protection	Feedback Loop Voltage Clamp		36		VDC
Start-Up	Resistive Load		20	30	mSec

¹ Input Voltage.

² Output Current.

Output Ripple & Noise

(Measured with no external capacitor, 20MHz B.W.)

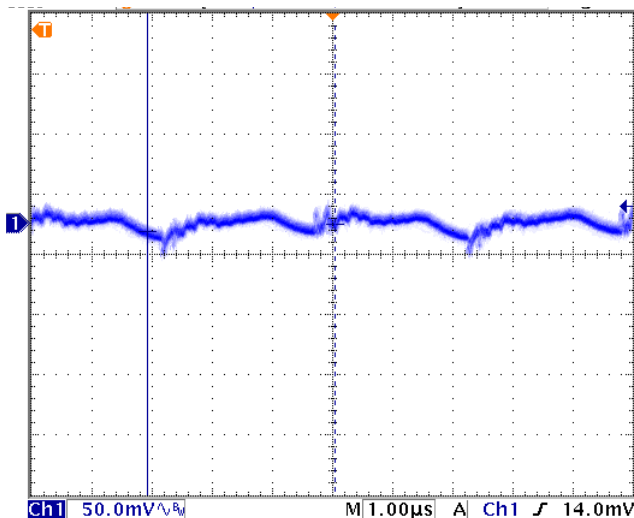

Output Load Transient

(75% to 100% Step Load change)

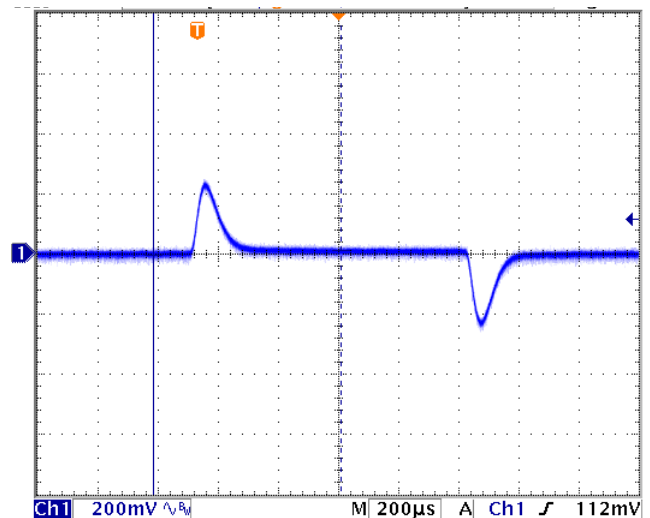

Start-Up

(Resistive, Full Load)

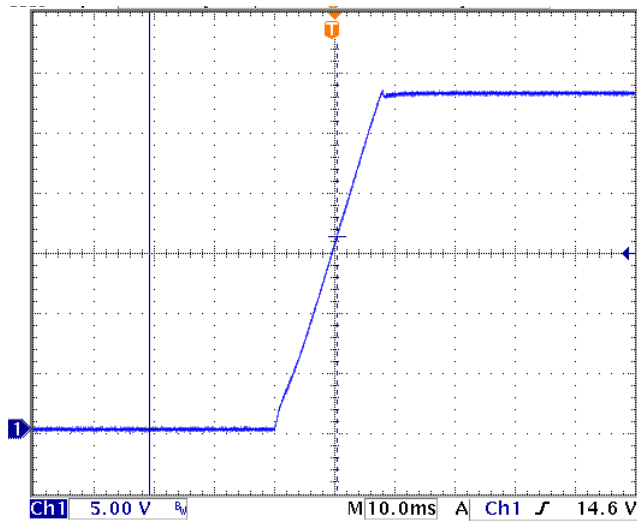

Efficiency Curves

(Measured @ Baseplate Temp < 50°C)

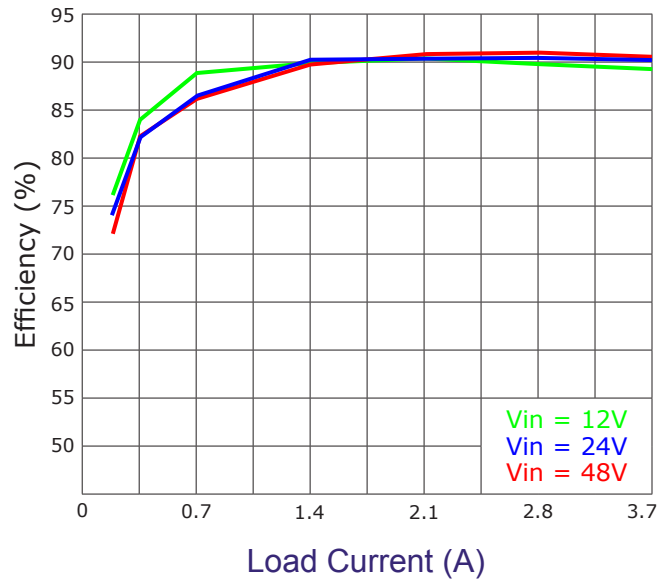

Output Voltage Trim

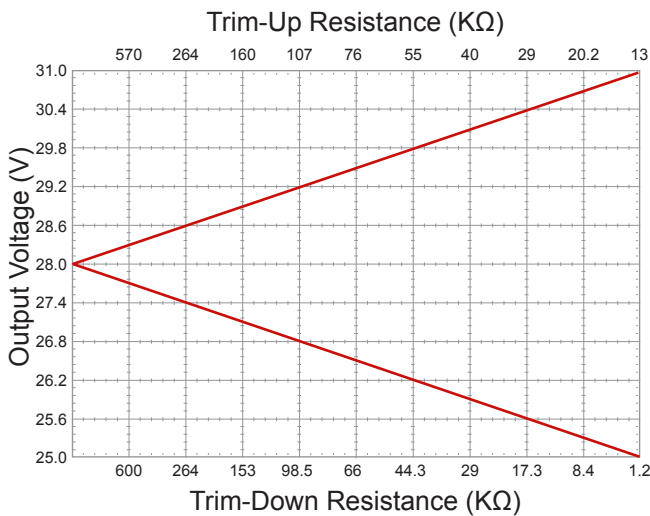

28V Trim

GENERAL SPECIFICATIONS:

All specifications apply over specified input voltage, output load, and temperature range, unless otherwise noted.

Parameter	Condition/Description	Min	Nom	Max	Unit
Operating Frequency	Fixed		200		KHz
Isolation Voltage	Input to Ouput	1500			VDC
	Metal Case to Input/Output	500			VDC
Isolation Resistance	Input to Ouput	10			MΩ
Isolation Capacitance	Input to Ouput		2200		pF
MTBF	Bellcore TR_NWT-000332		1,500		KHrs

¹ Input Voltage.

² Output Current.

ENVIROMENTAL SPECIFICATIONS:

All specifications apply over specified input voltage, output load, and temperature range, unless otherwise noted.

Parameter	Condition/Description	Min	Nom	Max	Unit
Temperature Coefficient	-55°C to +100°C Baseplate Temp.		0.02		%/°C
Operating Baseplate Temperature Range	Standard	-40		+85	°C
	Extended	-55		+100	°C
Storage Temperature Range		-55		+125	°C
Thermal Impedance	Per Watt Dissipation ¹		5		°C/W
Over Temperature Protection	Activated @ Baseplate Temperature		+105		°C
	Recovered @ Baseplate Temperature		+95		°C
Humidity	Relative Humidity, Non-Condensing	10		95	%
Shock	(Half-sinewave, 6ms), 3 axes	50			g
Vibration	GR-63-CORE, Section 5.4.2	1			g

¹ Not per Watt Output. Total Dissipation (W) = Total Output Power * (1/Efficiency - 1).

MECHANICAL SPECIFICATIONS

Parameter	Condition/Description	Min	Nom	Max	Units
Dimentions	Please see Drawing on p.31				
Weight	GH50S	Encapsulated		5.1 (145)	Oz (g)
		Chassis Mount		5.6 (160)	Oz (g)
	GH100S	Encapsulated		5.7 (162)	Oz (g)
		Chassis Mount		6.20(176)	Oz (g)
		DIN Rail Kit		1.0 (28)	Oz (g)

OPTIONS :

DESCRIPTION	OPTION (suffix)	NOTES
Extended Temperature	C	Operating Baseplate Temperature from -55°C to +100°C
Chassis Mount	TS	Potted and with #6-32 Screw Terminals for Input/Output connection
DIN Rail Mount	DR	TS option with DIN Rail Kit

Product Numbering System :

GH	100	S	24	05	C, TS, DR
Series	100W Output	Single Output	18 - 36Vin	5.0Vout	Options

Output Voltage Trim

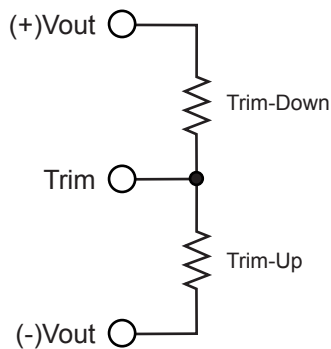

Simplified Ripple & Noise Measurement

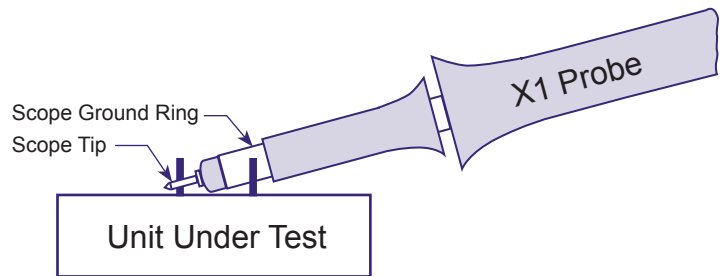

Encapsulated (Standard, No Suffix)

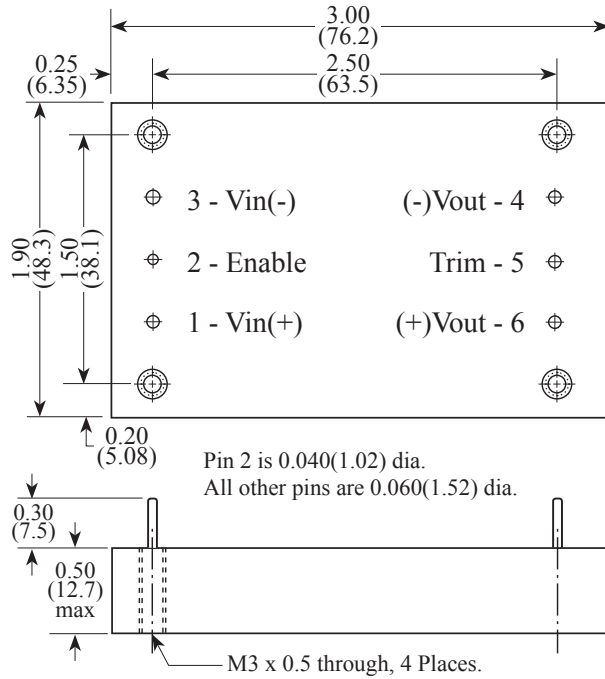

Chassis Mount (Optional, Suffix TS)

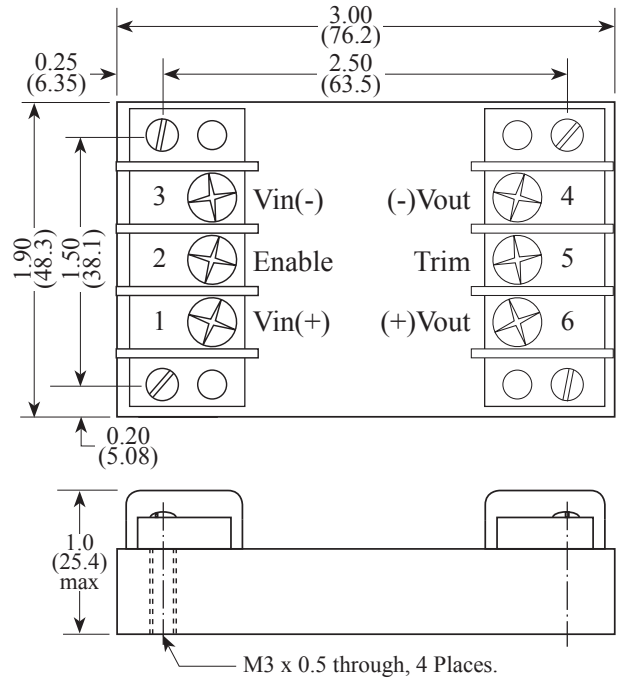

DIN Rail Kit (Optional, Suffix DR)

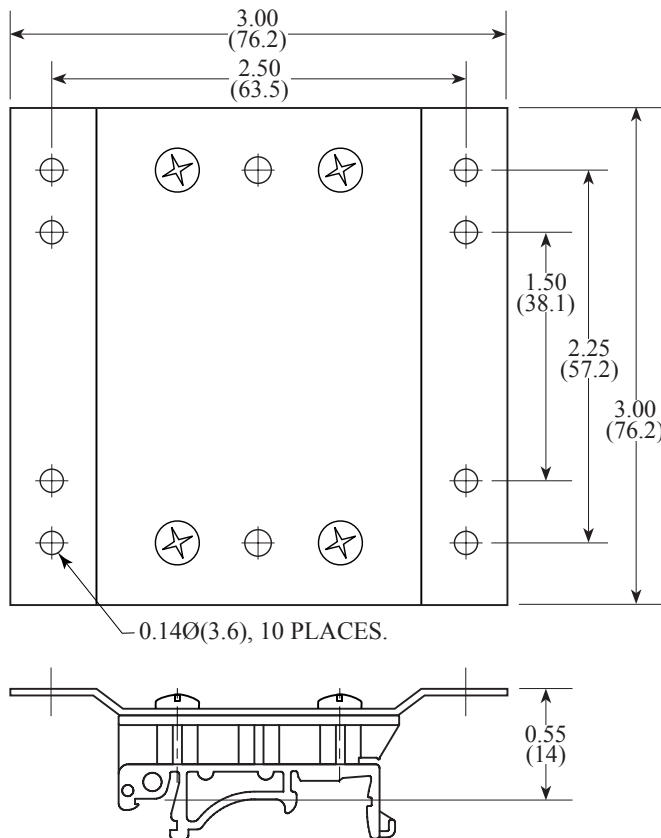

ALL DIMENSION IN INCHES (mm)
 Tolerance .xx = ±0.05
 .xxx = ±0.005