

### Preliminary Data

#### Overview

#### Features

- Delivers up to 5 A continuous 6 A peak current
- Optimized for DC motor management applications
- Operates at supply voltages up to 40 V
- Very low  $R_{DS\ ON}$ ; typ. 200 m $\Omega$  @ 25 °C per switch
- Output full short circuit protected
- Overtemperature protection with hysteresis and diagnosis
- Short circuit and open load diagnosis with open drain error flag
- Undervoltage lockout
- CMOS/TTL compatible inputs with hysteresis
- No crossover current
- Internal freewheeling diodes
- Wide temperature range;  $-40\text{ }^{\circ}\text{C} < T_j < 150\text{ }^{\circ}\text{C}$

Type	Ordering Code	Package
TLE 5205-2	Q67000-A9283	P-TO220-7-11
<b>TLE 5205-2GP</b>	<b>Q67006-A9237</b>	<b>P-DSO-20-10</b>
<b>TLE 5205-2G</b>	<b>Q67006-A9325</b>	<b>P-TO263-7-1</b>
TLE 5205-2S	Q67000-A9324	P-TO220-7-12

#### Description

The TLE 5205-2 is an integrated power H-bridge with DMOS output stages for driving DC-Motors. The part is built using the SIEMENS multi-technology process SPT® which allows bipolar and CMOS control circuitry plus DMOS power devices to exist on the same monolithic structure.

Operation modes forward (cw), reverse (ccw), brake and high impedance are invoked from just two control pins with TTL/CMOS compatible levels. The combination of an extremely low  $R_{DS\ ON}$  and the use of a power IC package with low thermal resistance and high thermal capacity helps to minimize system power dissipation. A blocking capacitor at the supply voltage is the only external circuitry due to the integrated freewheeling diodes.

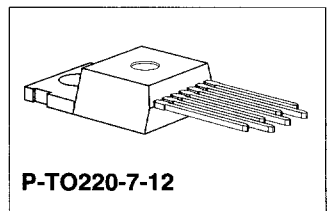
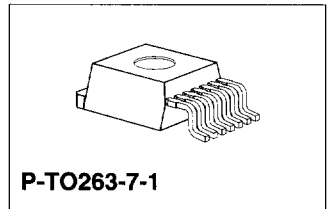
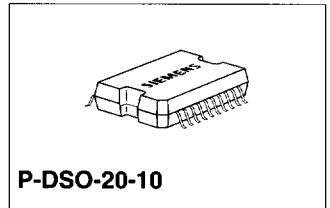
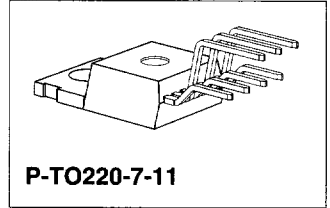

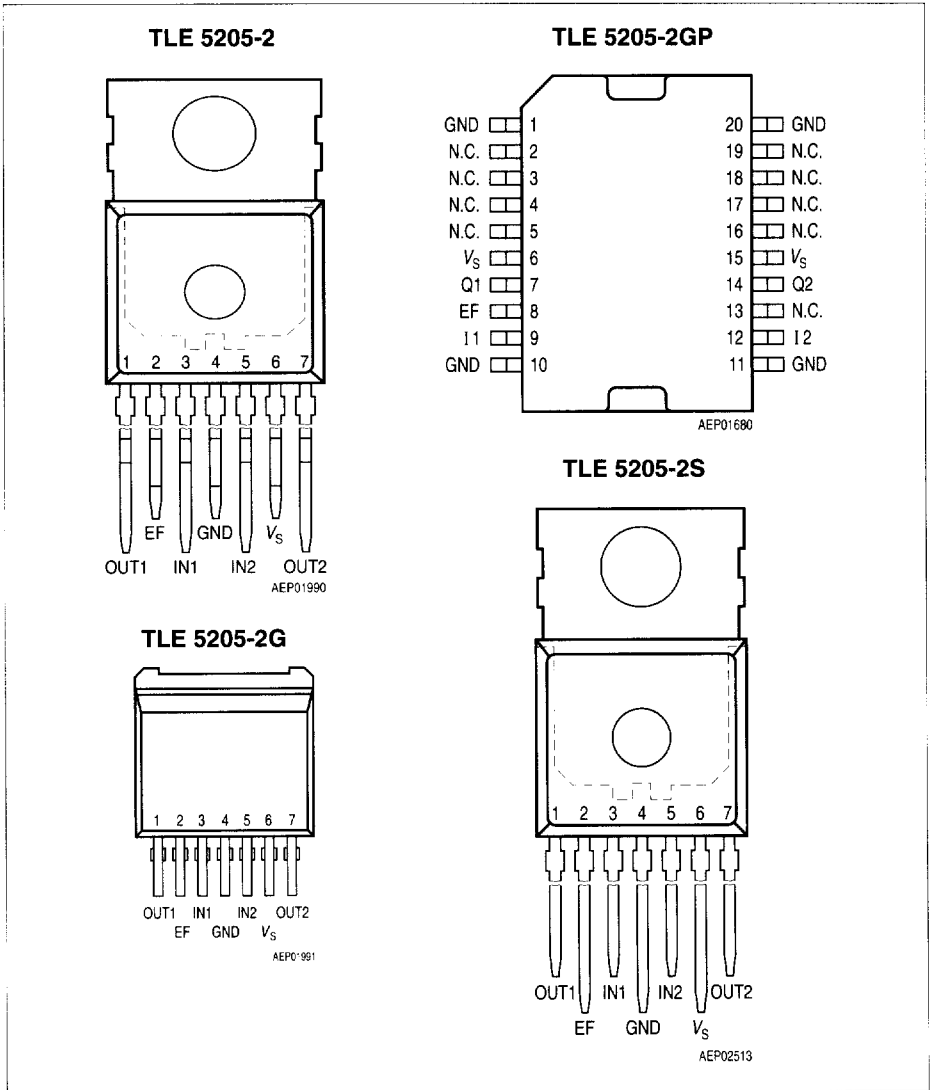

Figure 1 Pin Configuration (top view)

**Pin Definitions and Functions**

<b>Pin No. P-T0220</b>	<b>Pin No. P-DSO</b>	<b>Symbol</b>	<b>Function</b>
1	7	OUT1	<b>Output of channel 1;</b> Short-circuit protected; integrated freewheeling diodes for inductive loads.
2	8	EF	<b>Error flag;</b> TTL/CMOS compatible output for error detection; (open drain)
3	9	IN1	<b>Control input 1;</b> TTL/CMOS compatible
4	1, 10, 11, 20	GND	<b>Ground;</b> internally connected to tab
5	12	IN2	<b>Control input 2;</b> TTL/CMOS compatible
6	6, 15	$V_S$	<b>Supply voltage;</b> block to GND
7	14	OUT2	<b>Output of channel 2;</b> Short-circuit protected; integrated freewheeling diodes for inductive loads.
–	2, 3, 4, 5, 16, 17, 18, 19	N.C.	<b>Not connected</b>

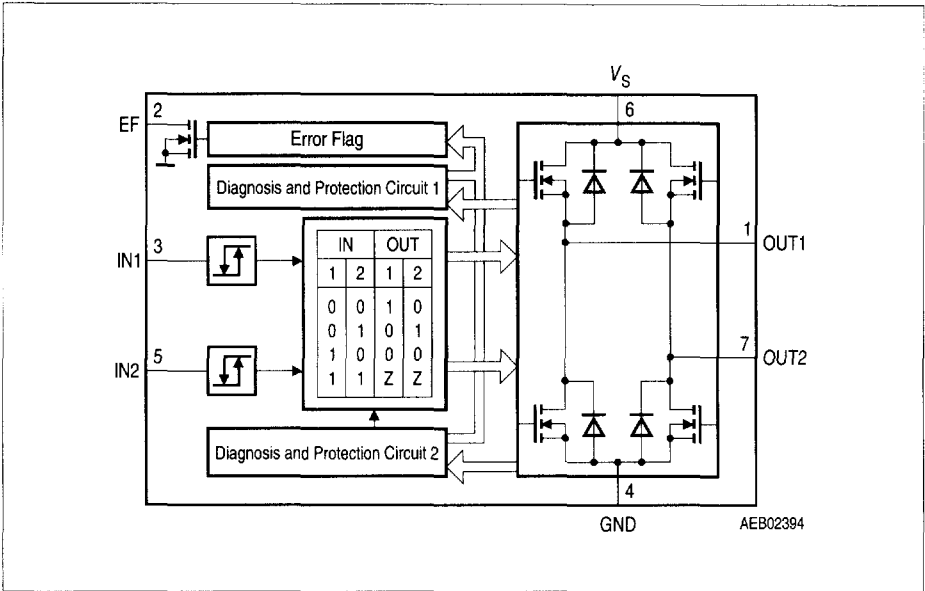

Figure 2 Block Diagram

**Circuit Description**

**Input Circuit**

The control inputs consist of TTL/CMOS-compatible schmitt-triggers with hysteresis. Buffer amplifiers are driven by this stages.

**Output Stages**

The output stages consist of a DMOS H-bridge. Integrated circuits protect the outputs against short-circuit to ground and to the supply voltage. Positive and negative voltage spikes, which occur when switching inductive loads, are limited by integrated freewheeling diodes.

A monitoring circuit for each output transistor detects whether the particular transistor is active and in this case prevents the corresponding source transistor (sink transistor) from conducting in sink operation (source operation). Therefore no crossover currents can occur.

## Input Logic Truth Table

### Functional Truth Table

IN1	IN2	OUT1	OUT2	Comments
L	L	H	L	Motor turns clockwise
L	H	L	H	Motor turns counterclockwise
H	L	L	L	Brake; both low side transistors turned-ON
H	H	Z	Z	Open circuit detection

### Notes for Output Stage

Symbol	Value
L	Low side transistor is turned-ON High side transistor is turned-OFF
H	High side transistor is turned-ON Low side transistor is turned-OFF
Z	High side transistor is turned-OFF Low side transistor is turned-OFF

### Monitoring Functions

Undervoltage lockout (UVLO):

When  $V_S$  reaches the switch on voltage  $V_{S\text{ ON}}$  the IC becomes active with a hysteresis. All output transistors are switched off if the supply voltage  $V_S$  drops below the switch off value  $V_{S\text{ OFF}}$ .

### Protective Function

Various errors like short-circuit to +  $V_S$ , ground or across the load are detected. All faults result in turn-OFF of the output stages after a delay of 50  $\mu\text{s}$  and setting of the error flag EF to ground. Changing the inputs resets the error flag.

#### a. Output Shorted to Ground Detection

If a high side transistor is switched on and its output is shorted to ground, the output current is internally limited. After a delay of 50  $\mu\text{s}$  all outputs will be switched-OFF and the error flag is set.

#### b. Output Shorted to + $V_S$ Detection

If a low side transistor is switched on and its output is shorted to the supply voltage, the output current is internally limited. After a delay of 50  $\mu\text{s}$  all outputs will be switched-OFF and the error flag is set.

**c. Overload Detection**

An internal circuit detects if the current through the low side transistor exceeds the trippoint  $I_{SDL}$ . In this case all outputs are turned off after 50  $\mu$ s and the error flag is set.

**d. Overtemperature Protection**

At a junction temperature higher than 150 °C the thermal shutdown turns-OFF, all four output stages commonly and the error flag is set with a delay.

**e. Open Load Detection**

The output Q1 has a 10 k $\Omega$  pull-up resistor and the output Q2 has a 10 k $\Omega$  pull-down resistor. If E1 and E2 are high, all output power stages are turned-OFF. In case of no load between Q1 and Q2 the output voltage Q1 is  $V_S$  and Q2 is ground. This state will be detected by two comparators and an error flag will be set after a delay time of 50  $\mu$ s. Changing the inputs resets the error flip flop.

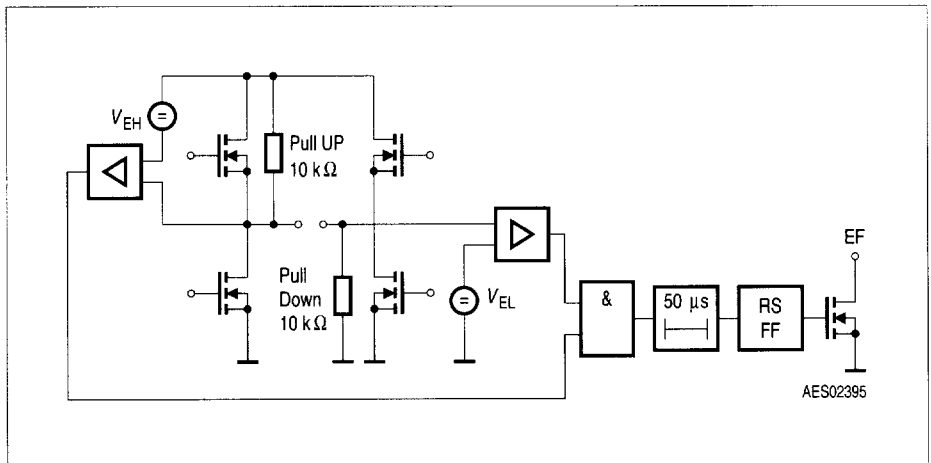

**Figure 3 Simplified Schematic for Open Load Detection**

## Diagnosis

Various errors as listed in the table "Diagnosis" are detected. Short circuits and overload result in turning off the output stages after a delay ( $t_{\text{doff}}$  for short circuit and  $t_{\text{doc}}$  for open circuit) and setting the error flag simultaneously [EF = L]. Changing the inputs to a state where the fault is not detectable resets the error flag (input toggling) with the exception of short circuit from OUT1 to OUT2 (load short circuit).

Flag	IN1	IN2	OUT1	OUT2	EF	Remarks	Nr.
Open circuit between OUT1 and OUT2	0	0	H	L	1	Not detectable	1
	0	1	L	H	1	Not detectable	2
	1	0	L	L	1	Not detectable	3
	1	1	Z	Z	0		4
Short circuit from OUT1 to OUT2	0	0	$V_s/2$	$V_s/2$	0		5
	0	1	$V_s/2$	$V_s/2$	0		6
	1	0	L	L	1	Not detectable	7
	1	1	Z	Z	1	Not detectable	8
Short circuit from OUT1 to GND	0	0	GND	L	0		9
	0	1	GND	H	1	Not detectable	10
	1	0	GND	L	1	Not detectable	11
	1	1	GND	L	1	Not detectable	12
Short circuit from OUT2 to GND	0	0	H	GND	1	Not detectable	13
	0	1	L	GND	0		14
	1	0	L	GND	1	Not detectable	15
	1	1	L	GND	1	Not detectable	16
Short circuit from OUT1 to $V_s$	0	0	$V_s$	L	1	Not detectable	17
	0	1	$V_s$	H	0		18
	1	0	$V_s$	H	0		19
	1	1	$V_s$	H	1	Not detectable	20
Short circuit from OUT2 to $V_s$	0	0	H	$V_s$	0		21
	0	1	L	$V_s$	1	Not detectable	22
	1	0	H	$V_s$	0		23
	1	1	H	$V_s$	1	Not detectable	24
Overtemperature or undervoltage	0	0	Z	Z	0		25
	0	1	Z	Z	0		26
	1	0	Z	Z	0		27
	1	1	Z	Z	0		28

IN: 0 = Logic LOW    OUT: Z = Output in tristate condition  
 1 = Logic HIGH        =  $V_s/2$  due to internal Pull-up/down resistors

EF: 1 = No error  
 0 = Error

L = Output in sink condition

H = Output in source condition

## Electrical Characteristics

### Absolute Maximum Ratings

$-40\text{ °C} < T_j < 150\text{ °C}$

Parameter	Symbol	Limit Values		Unit	Remarks
		min.	max.		

### Voltages

Supply voltage	$V_S$	- 0.3	40	V	-
		- 1	40	V	$t < 0.5\text{ s}; I_S > -5\text{ A}$
Logic input voltage	$V_{IN1,2}$	- 0.3	7	V	$0\text{ V} < V_S < 40\text{ V}$
Diagnostics output voltage	$V_{EF}$	- 0.3	7	V	-

### Currents of DMOS-Transistors and freewheeling diodes

Output current (cont.)	$I_{OUT1,2}$	- 5	5	A	-
Output current (peak)	$I_{OUT1,2}$	- 6	6	A	$t_p < 100\text{ ms}; T = 1\text{ s}$
Output current (peak)	$I_{OUT1,2}$	-	-	A	$t_p < 50\text{ }\mu\text{s}; T = 1\text{ s};$ internally limited; see overcurrent

### Temperatures

Junction temperature	$T_j$	- 40	150	°C	-
Storage temperature	$T_{stg}$	- 50	150	°C	-

### Thermal Resistances

Junction case	$R_{thjC}$	-	3	K/W	P-TO220-7-11/12, P-TO263-7-1
Junction ambient	$R_{thjA}$	-	65	K/W	P-TO220-7-11/12
		-	75	K/W	P-TO263-7-1
Junction case	$R_{thjC}$	-	5	K/W	P-DSO-20-10
Junction ambient	$R_{thjA}$	-	50	K/W	P-DSO-20-10

*Note: Maximum ratings are absolute ratings; exceeding any one of these values may cause irreversible damage to the integrated circuit.*



## Operating Range

Parameter	Symbol	Limit Values		Unit	Remarks
		min.	max.		
Supply voltage	$V_S$	$V_{UV\ ON}$	40	V	After $V_S$ rising above $V_{UV\ ON}$
Supply voltage increasing		- 0.3	$V_{UV\ ON}$	V	Outputs in tristate condition
Supply voltage decreasing		- 0.3	$V_{UV\ OFF}$	V	
Logic input voltage	$V_{IN1,2}$	- 0.3	7	V	-
Junction temperature	$T_j$	- 40	150	°C	-

## Electrical Characteristics

6 V <  $V_S$  < 18 V; IN1 = IN2 = HIGH

$I_{OUT1,2} = 0$  A (No load); - 40 °C <  $T_j$  < 150 °C; unless otherwise specified

Parameter	Symbol	Limit Values			Unit	Test Condition
		min.	typ.	max.		

## Current Consumption

Quiescent current	$I_S$	-	-	10	mA	IN1 = IN2 = LOW; $V_S = 13.2$ V
-------------------	-------	---	---	----	----	------------------------------------

## Under Voltage Lockout

UV-Switch-ON voltage	$V_{UV\ ON}$	-	5	6	V	$V_S$ increasing
UV-Switch-OFF voltage	$V_{UV\ OFF}$	3.5	4.4	-	V	$V_S$ decreasing
UV-ON/OFF-Hysteresis	$V_{UV\ HY}$	0.2	0.6	-	V	$V_{UV\ ON} - V_{UV\ OFF}$

## Electrical Characteristics (cont'd)

$6\text{ V} < V_S < 18\text{ V}$ ;  $IN1 = IN2 = \text{HIGH}$

$I_{OUT1,2} = 0\text{ A}$  (No load);  $-40\text{ }^\circ\text{C} < T_j < 150\text{ }^\circ\text{C}$ ; unless otherwise specified

Parameter	Symbol	Limit Values			Unit	Test Condition
		min.	typ.	max.		

## Outputs OUT1, 2

### Static Drain-Source-On Resistance

Source $I_{OUT} = -3\text{ A}$	$R_{DS\ ON\ H}$	-	200	400	$\text{m}\Omega$	$6\text{ V} < V_S < 18\text{ V}$ $T_j = 25\text{ }^\circ\text{C}$
			-	650	$\text{m}\Omega$	$6\text{ V} < V_S < 18\text{ V}$
			350	500	$\text{m}\Omega$	$V_{S\ ON} < V_S \leq 6\text{ V}$ $T_j = 25\text{ }^\circ\text{C}$
			-	800	$\text{m}\Omega$	$V_{S\ ON} < V_S \leq 6\text{ V}$
Sink $I_{OUT} = 3\text{ A}$	$R_{DS\ ON\ L}$	-	200	400	$\text{m}\Omega$	$6\text{ V} < V_S < 18\text{ V}$ $T_j = 25\text{ }^\circ\text{C}$
			-	650	$\text{m}\Omega$	$6\text{ V} < V_S < 18\text{ V}$
			400	600	$\text{m}\Omega$	$V_{S\ ON} < V_S \leq 6\text{ V}$ $T_j = 25\text{ }^\circ\text{C}$
			-	1000	$\text{m}\Omega$	$V_{S\ ON} < V_S \leq 6\text{ V}$

Note: Values of  $R_{DS\ ON}$  for  $V_{S\ ON} < V_S \leq 6\text{ V}$  are guaranteed by design.

### Overcurrent

Source shutdown trippoint	$-I_{SDH}$	6	9	-	A	-
Sink shutdown trippoint	$I_{SDL}$	6	9	-	A	-
Shutdown delay time	$t_{dSD}$	25	50	80	$\mu\text{s}$	-

### Short Circuit

Source current	$-I_{SCH}$	-	-	20	A	$t < t_{dSD}$
Sink current	$I_{SCL}$	-	-	15	A	$t < t_{dSD}$

## Electrical Characteristics (cont'd)

$6\text{ V} < V_S < 18\text{ V}$ ;  $IN1 = IN2 = \text{HIGH}$

$I_{OUT1,2} = 0\text{ A}$  (No load);  $-40\text{ }^\circ\text{C} < T_j < 150\text{ }^\circ\text{C}$ ; unless otherwise specified

Parameter	Symbol	Limit Values			Unit	Test Condition
		min.	typ.	max.		

### Open Circuit

Pull up resistor	$R_{UP}$	5	10	20	k $\Omega$	–
Pull down resistor	$R_{DOWN}$	5	10	20	k $\Omega$	–
Switching threshold H	$V_{EH}$	2	2.5	3.5	V	–
Switching threshold L	$V_{EL}$	2	2.4	3.5	V	–

### Output Delay Times (device active for $t > 1\text{ ms}$ )

Source ON	$t_{d\text{ ON H}}$	–	7.5	20	$\mu\text{s}$	$I_{OUT} = -3\text{ A}$ resistive load
Sink ON	$t_{d\text{ ON L}}$	–	7.5	20	$\mu\text{s}$	$I_{OUT} = 3\text{ A}$ resistive load
Source OFF	$t_{d\text{ OFF H}}$	–	5	20	$\mu\text{s}$	$I_{OUT} = -3\text{ A}$ resistive load
Sink OFF	$t_{d\text{ OFF L}}$	–	5	20	$\mu\text{s}$	$I_{OUT} = 3\text{ A}$ resistive load

### Output Switching Times (device active for $t > 1\text{ ms}$ )

Source ON	$t_{ON\text{ H}}$	–	15	30	$\mu\text{s}$	$I_{OUT} = -3\text{ A}$ resistive load
Sink ON	$t_{ON\text{ L}}$	–	5	10	$\mu\text{s}$	$I_{OUT} = 3\text{ A}$ resistive load
Source OFF	$t_{OFF\text{ H}}$	–	2	10	$\mu\text{s}$	$I_{OUT} = -3\text{ A}$ resistive load
Sink OFF	$t_{OFF\text{ L}}$	–	2	10	$\mu\text{s}$	$I_{OUT} = 3\text{ A}$ resistive load

## Electrical Characteristics (cont'd)

$6\text{ V} < V_S < 18\text{ V}$ ;  $IN1 = IN2 = \text{HIGH}$

$I_{OUT1,2} = 0\text{ A}$  (No load);  $-40\text{ }^\circ\text{C} < T_j < 150\text{ }^\circ\text{C}$ ; unless otherwise specified

Parameter	Symbol	Limit Values			Unit	Test Condition
		min.	typ.	max.		

## Clamp Diodes

### Forward Voltage

High-side	$V_{FH}$	–	1	1.5	V	$I_F = 3\text{ A}$
Low-side	$V_{FL}$	–	1.1	1.5	V	$I_F = 3\text{ A}$

### Leakage Current

Source	$I_{LKH}$	–200	–	–	$\mu\text{A}$	$OUT1 = V_S$
Sink	$I_{LKL}$	–	–	200	$\mu\text{A}$	$OUT2 = \text{GND}$

## Logic

### Control Inputs IN 1, 2

H-input voltage threshold	$V_{INH}$	2.8	–	–	V	–
L-input voltage	$V_{INL}$	–	–	1.2	V	–
Hysteresis of input voltage	$V_{INHY}$	0.4	0.8	1.2	V	–
H-input current	$I_{INH}$	–2	–	2	$\mu\text{A}$	$V_{IN} = 5\text{ V}$
L-input current	$I_{INL}$	–10	–4	0	$\mu\text{A}$	$V_{IN} = 0\text{ V}$

### Error Flag Output EF

Low output voltage	$V_{EFL}$	–	0.25	0.5	V	$I_{EF} = 3\text{ mA}$
Leakage current	$I_{EFL}$	–	–	10	$\mu\text{A}$	$V_{EF} = 7\text{ V}$

### Thermal Shutdown

Thermal shutdown junction temperature	$T_{jSD}$	150	175	200	$^\circ\text{C}$	–
---------------------------------------	-----------	-----	-----	-----	------------------	---

### Electrical Characteristics (cont'd)

$6\text{ V} < V_S < 18\text{ V}$ ;  $IN1 = IN2 = \text{HIGH}$

$I_{OUT1,2} = 0\text{ A}$  (No load);  $-40\text{ }^\circ\text{C} < T_j < 150\text{ }^\circ\text{C}$ ; unless otherwise specified

Parameter	Symbol	Limit Values			Unit	Test Condition
		min.	typ.	max.		
Thermal switch-on junction temperature	$T_{jSO}$	120	–	170	$^\circ\text{C}$	–
Temperature hysteresis	$\Delta T$	–	30	–	K	–

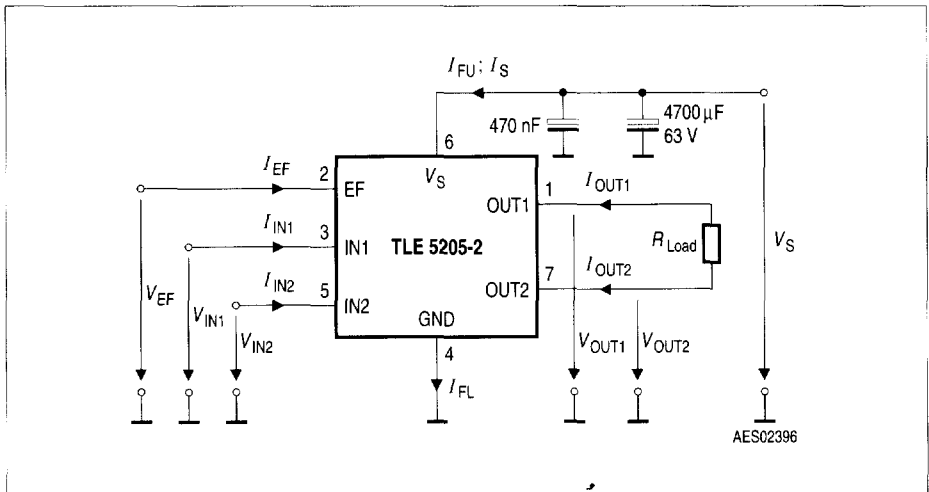

**Figure 4 Test Circuit**

	Overcurrent	Short Circuit	Open Circuit
$I_{OUT}$	$I_{SD}$	$I_{SC}$	$I_{OC}$

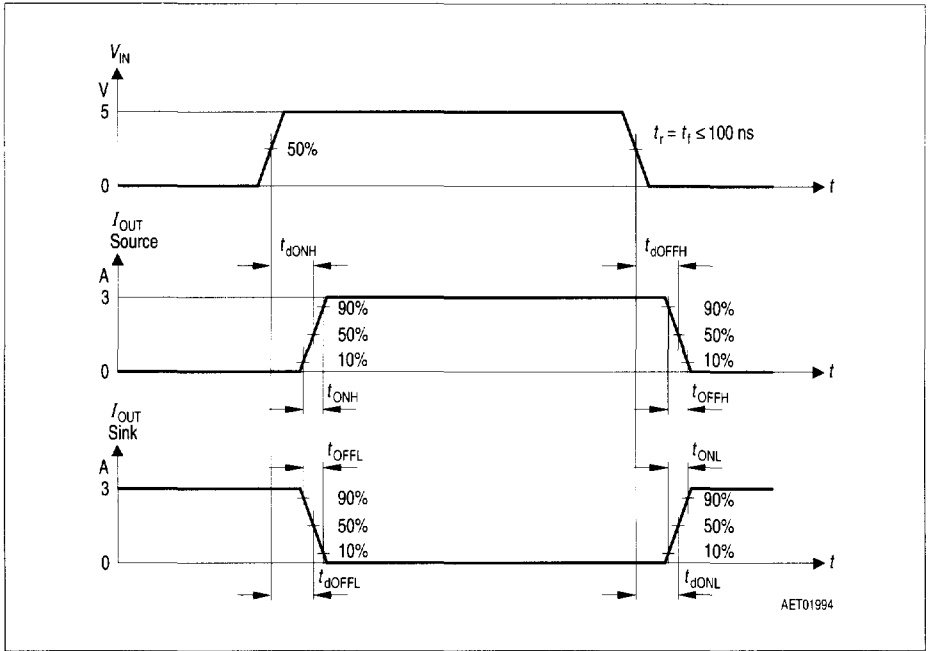

Figure 5 Switching Time Definitions

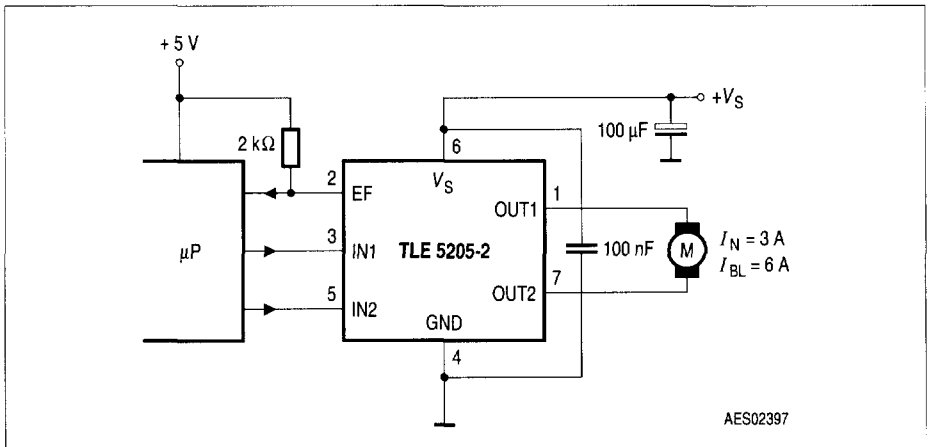

Figure 6 Application Circuit

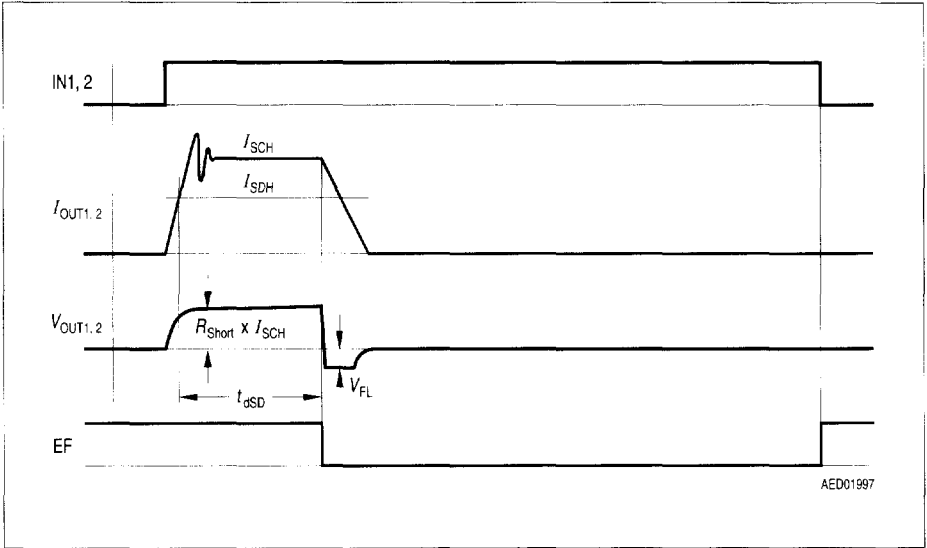

Figure 7 Timing Diagram for Output Shorted to Ground

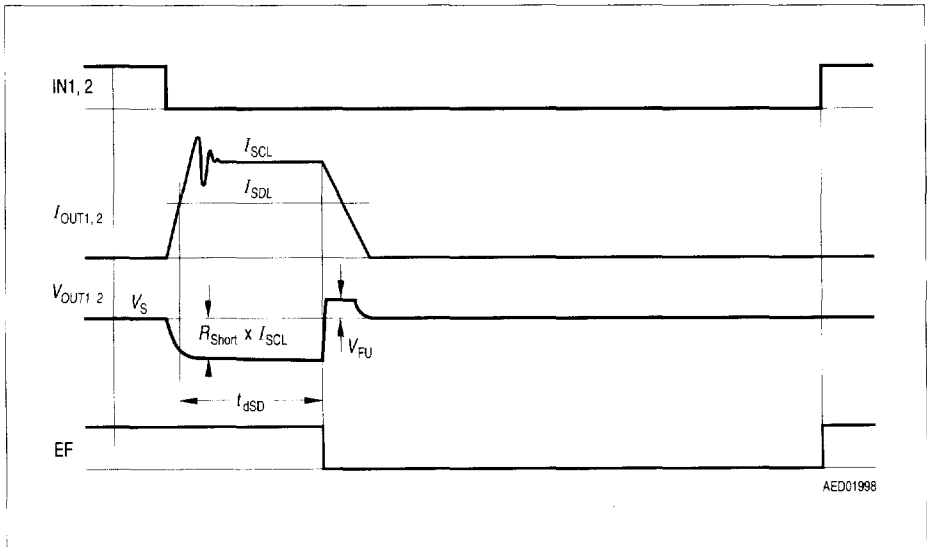
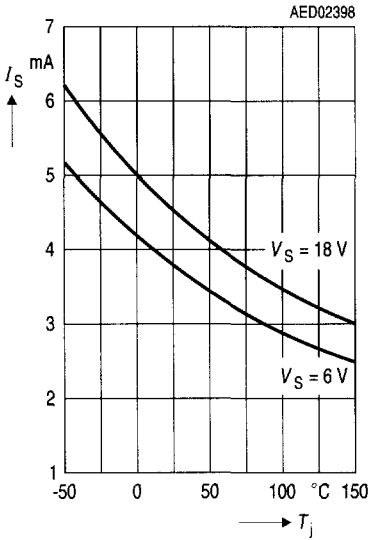

Figure 8 Timing Diagram for Output Shorted to  $V_S$

Diagrams

Quiescent Current  $I_S$  (active) versus Junction Temperature  $T_j$



Static Drain-Source ON-Resistance versus Junction Temperature  $T_j$

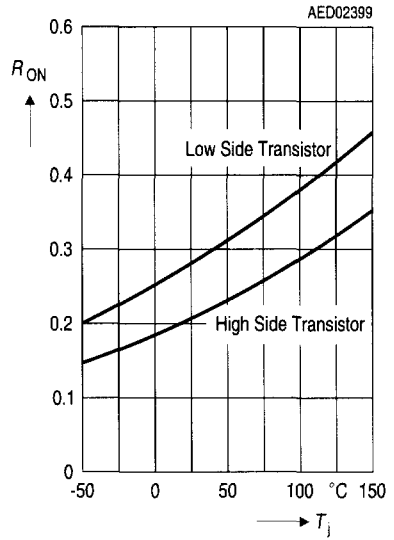

Input Switching Thresholds  $V_{INH, L}$  versus Junction Temperature  $T_j$

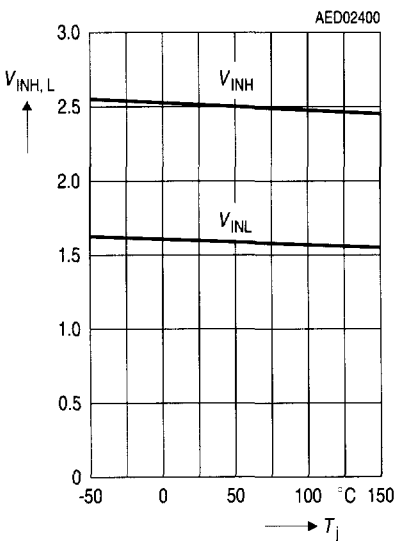

Clamp Diode Forward Voltage  $V_F$  versus Junction Temperature  $T_j$

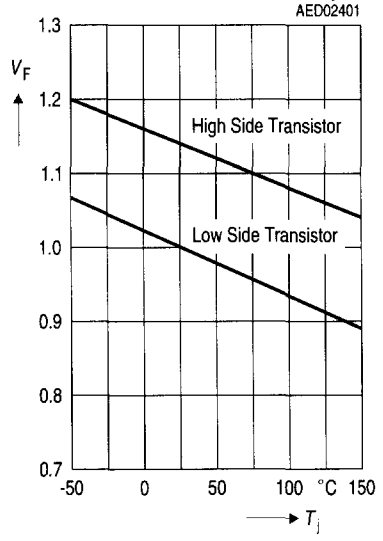



**Overcurrent Shutdown Threshold  $I_{SD}$  versus Junction Temperature  $T_j$**

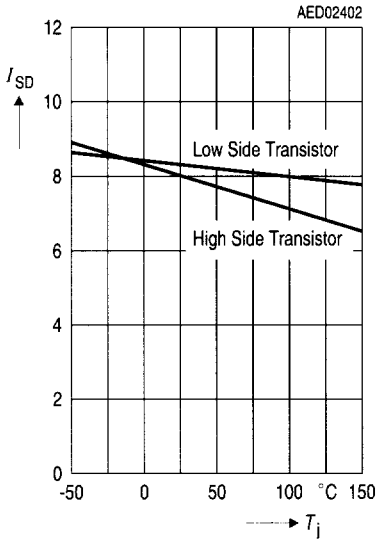

**Error-Flag Saturation Output Voltage  $V_{EF}$  versus Junction Temperature  $T_j$**

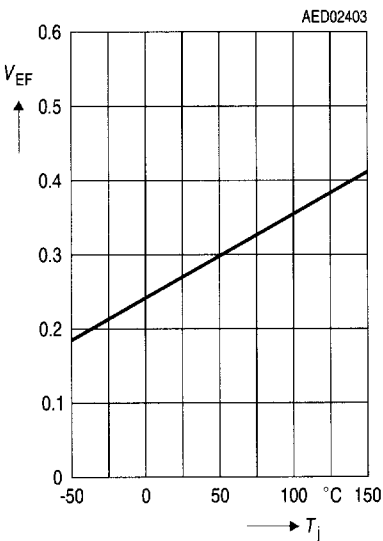

**Switching Threshold  $V_{EH}$ ,  $V_{EL}$  versus Junction Temperature  $T_j$**

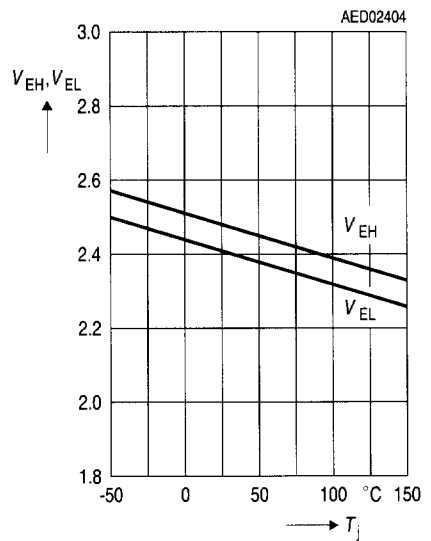

Package Outlines

P-TO220-7-11

(Plastic Transistor Single Outline Package)

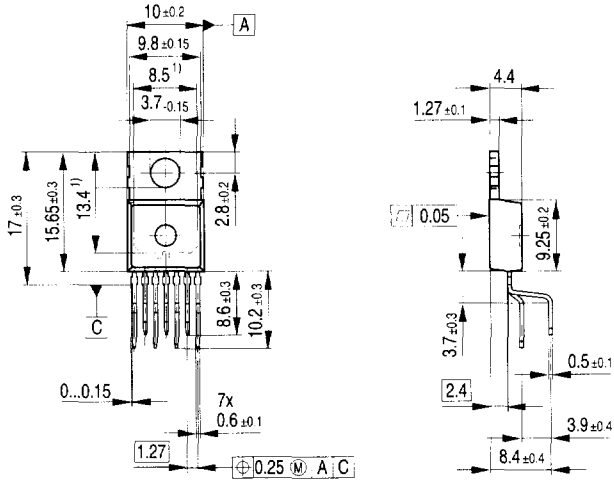

<sup>1)</sup> Typical

All metal surfaces tin plated, except area of cut.

GPT09083

Sorts of Packing

Package outlines for tubes, trays etc. are contained in our Data Book "Package Information".

Dimensions in mm

**P-DSO-20-10**  
**(Plastic Dual Small Outline Package)**

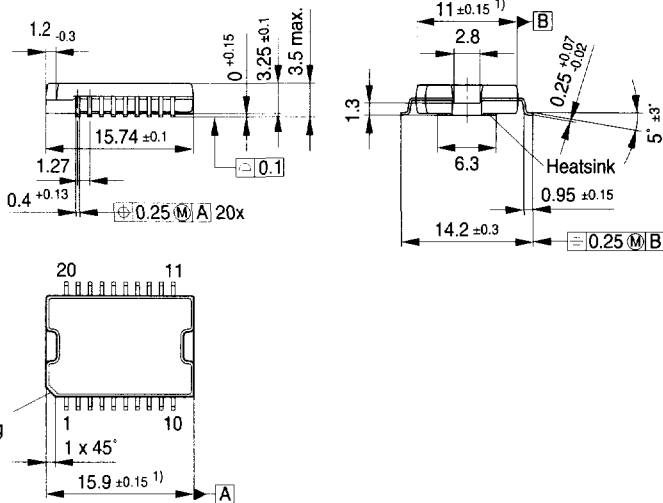

1) Does not include plastic or metal protrusion of 0.15 max. per side

GPS95791

**Sorts of Packing**

Package outlines for tubes, trays etc. are contained in our Data Book "Package Information".

**SMD = Surface Mounted Device**

Dimensions in mm

**P-TO263-7-1 Option E3180**  
**(Plastic Transistor Single Outline Package)**

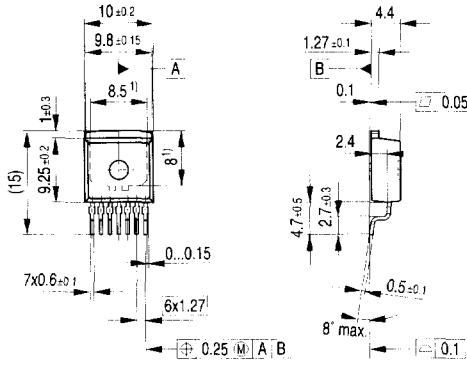

<sup>1)</sup> Typical  
 All metal surfaces tin plated, except area of cut.

GPT09114

**Sorts of Packing**

Package outlines for tubes, trays etc. are contained in our Data Book "Package Information".

**SMD = Surface Mounted Device**

Dimensions in mm

**P-TO220-7-12**

(Plastic Transistor Single Outline Package)

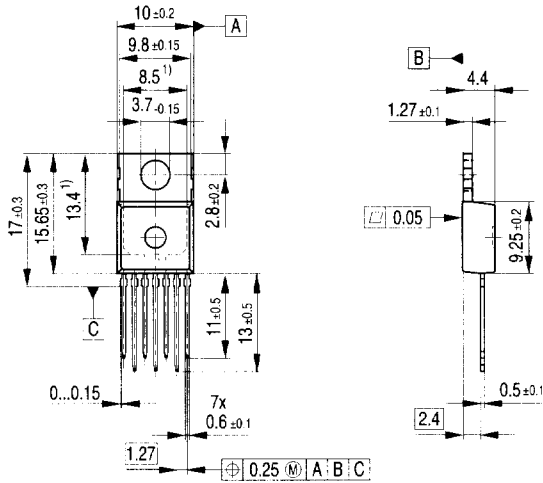

<sup>1)</sup> Typical

All metal surfaces tin plated, except area of cut.

GPT09064

**Sorts of Packing**

Package outlines for tubes, trays etc. are contained in our Data Book "Package Information".

Dimensions in mm