

# SWITCHES

SPDT, DC to 5 GHz

# YSWA-2-50DR+ YSWA-2-50DR

## PIN CONFIGURATION

PORT	ef
RF IN	4
RF OUT 1	12
RF OUT 2	14
Control	2
+5V	19
-5V	7
NOT USED	9,17
GND EXT.	All other pins

## OUTLINE DRAWING

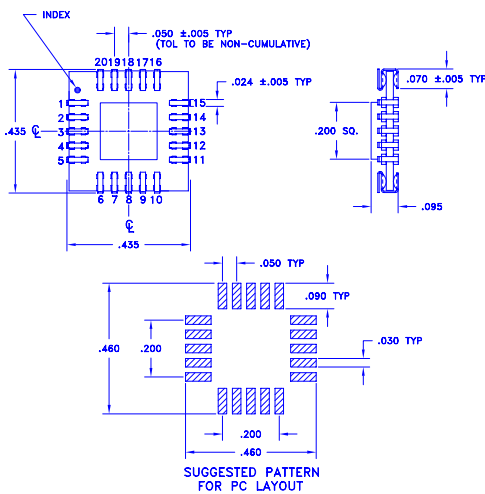

## FEATURES

- high isolation, 80 dB typical at 5 MHz
- low video break thru, 30 mV P-P typical.
- solder plated J-leads for good solderability & strain relief

CASE STYLE: 99-01-560

+ RoHS compliant in accordance with EU Directive (2002/95/EC)

The +Suffix identifies RoHS Compliance. See our web site for RoHS Compliance methodologies and qualifications.

## SPECIFICATIONS

FREQ. GHz	ABSORPTIVE	INSERTION LOSS, dB						1dB COMPRESSION, dBm						IN-OUT ISOLATION, dB						CONNECTION
		FREQUENCY BAND						FREQUENCY BAND						FREQUENCY BAND						
		A		B		C		A		B		C		A		B		C		
DC-5	●	1.1	1.5	1.4	1.9	1.9	--	18	13	20	17	22.5	20	42	38	31	27	20	19	ef

A= DC - 500 MHz, B= 500 - 2000 MHz, C= 2000 - 5000 MHz

## additional specifications

Model Series	YSWA
Control Voltage	
Low threshold, V	0 min. , 0.8 max.
High threshold, V	3.5 min. , 5.5 max.
Control Current	
High V, mA	5 max.
Low V, mA	0.2 max.
Positive Supply V.	5+0.5; 5-0.1
Negative Supply V.	-5-0.5; -5+0.1
+5V power supply current, mA	14 typ., 20 max.
-5V power supply current, mA	13 typ., 20 max.
VSWR (:1)	1.4 typ., 2.0 max.*
Rise/ Fall time (10%-90%), ns	6 typ., 12 max.
Switching time, 50% of Control to 90% RF (Turn-on), ns	20 typ., 40 max.
to 10% RF (Turn-off), ns	
**Video Leakage, mVp-p	30 typ.
Temperature, °C operating	-20 to 85
storage	-55 to 100

## NOTES:

- \* For output ports when in "ON" condition, up to 3.5 GHz. For 3.5 - 5 GHz, 2.0:1 typ.
- \*\* Video leakage or break through is defined as leakage of TTL switching signal to RF output ports.
- Typical isolation in YSW at 5 MHz is 80 dB and decreases 5 dB/octave from 5-1000 MHz.
- 1. Absolute maximum power, voltage and current ratings: RF input power, +20 dBm @ 50 MHz, +27 dBm for f>500 MHz.

## control logic

Model Series	Control Port	RF outputs	
		1	2
YSWA	High	Off	On
	Low	On	Off



P.O. Box 350166, Brooklyn, New York 11235-0003 (718) 934-4500 Fax (718) 332-4661 For detailed performance specs & shopping online see Mini-Circuits web site



The Design Engineers Search Engine Provides ACTUAL Data Instantly From MINI-CIRCUITS At: [www.minicircuits.com](http://www.minicircuits.com)

IF/RF MICROWAVE COMPONENTS

REV. D  
M111708  
ED-6966/2  
YSWA250DR  
DJ/TD/CP  
090108